



राष्ट्रीय पशु जैव प्रौद्योगिकी संस्थान
National Institute of Animal Biotechnology



An Autonomous Institute of the Dept. of Biotechnology, Ministry of Science & Technology, Govt. of India

STORES AND PURCHASE SECTION

E-mail	spm@niab.org.in		Address
Telephone	+91 40 2304 9404		D. No: 1-121/1, 4 th & 5 th Floors, Axis Clinicals Building,
Telefax	+91 40 2304 2740		Miyapur, Hyderabad, Telangana,
Website	www.niab.org.in		India – 500049

NOTICE INVITING TENDER (SINGLE BID SYSTEM)

E-PROCUREMENT UNDER CENTRAL PUBLIC PROCUREMENT PORTAL

On behalf of the Director, NIAB - Hyderabad, India, **online bids** through www.eprocure.gov.in are invited under **Single Bid System** from reputed manufacturers or their authorized agents for the supply / installation/ commissioning of the following item(s) / Provide the Service /Work mentioned in Chapter-1 in this tender notice.

KINDLY NOTE THAT ONLY ONLINE BIDS WILL BE CONSIDERED AGAINST THIS TENDER.
MANUAL SUBMISSION OF BIDS WILL NOT BE ACCEPTED.

Website for Online Bid Submission: <https://eprocure.gov.in>.

E-Tendering Procedure: The procurement shall be carried out through submission of online tenders only. No offer in physical form will be accepted and any such offer if received by NIAB will be rejected. Tender documents can be downloaded from our website www.niab.org.in or website of CPPP www.eprocure.gov.in. The bidders will be required to submit their bids online on the e-Procurement module using website www.eprocure.gov.in. Only.

The bidders can enrol themselves on the website <http://eprocure.gov.in> using the option “Click here to Enroll”. Possession of a Valid Class II/III Digital Signature Certificate (DSC) in the form of smart card/e-token in the Company's name is a prerequisite for registration and participating in the bid submission activities through this web site. Digital Signature Certificates can be obtained from the authorized certifying agencies, details of which are available in the web site <http://eprocure.gov.in> under the link “Information about DSC”. The web site also has user manuals with detailed guidelines on enrolment and participation in the online bidding process. The user manuals can be downloaded for ready reference.

Please visit website: - <http://eprocure.gov.in/eprocure/app> and click following section for complete information about E -Procurement process.

- [Help For Contractors](#)
- [Information About DSC](#)
- [FAQ](#)
- [Bidders Manual Kit](#)

The helpdesk numbers for any technical queries related to operation of the Central Public Procurement Portal

Please call 24 x 7 - **Toll Free No. 1800 3070 2232.** **Help Desk Number 0120-4200462, 0120-4001002.**

Mobile Numbers- 8826246593 , 7878007972, 7878007973, 7574889871, 7574889874. E-Mail :-cPPP-nic@nic.in.

Any queries relating to the NIT document and the terms and conditions contained therein should be addressed to the Manager (Store& Purchase) of NIAB on the contact details mention on the top of this page.

CONTENTS OF BIDDING DOCUMENT/NIT

CHAPTER NO	PARTICULAR
1	NIT/DETAILS OF REQUIRMENTS /EMD/TENDER FEES/IMPORTANT DATES
2	INFORMATION FOR BIDDERS (PART-1)
3	INFORMATION FOR BIDDERS (PART-2)
4	GENERAL CONDITIONS OF CONTRACT
5	REQUIRED DOCUMENTS/FORMAT WITH BID (TO BE UPLOADED ONLINE) (format to keep ready before online submission of bids ,(Tenderers are required to print this on their company's letter head and sign, stamp ,scan , keep pdf file ready before starting of online tender submission)
6	SPECIFICATION AND OTHER TERMS OF REQUIREMENTS

IMPORTANT NOTE: - PLEASE READ CHAPTER 5 AND 6 CAREFULLY AND KEEP SCANNED FORMAT DOCUMENTS READY IN ONE PDF FILE BEFORE SUBMISSION OF THE BID.

Main Process flow to help you in submission of tender. -

- Take DD and scan it in pdf format. Write Tender No , Name of Firm , Contact No on backside of DD. Send the DD to NIAB- Hyderabad Address as per due date.
- Read Chapter No 5 & 6 carefully & Keep required documents ready, scan it in pdf file to be uploaded in Cover -1.

Few of the conditions/ forms in this document may not be applicable for Service/Work requirement as per this tender. Write “NA” in any of the form wherever it is suitable/applicable as per bid submitting firm considering the requirement in tender.

Please read very carefully evaluation criteria mentioned in chapter - 3 , point No 15 & 16. Considering these points, firms are informed to submit all relevant supporting documents which will give them better marks in technical criteria.

CHAPTER-1

NIT/DETAILS OF REQUIRMENTS /EMD/TENDER FEES/IMPORTANT DATES

S N	Name of item (<u>Detailed Specifications as per Chapter 6</u>)	Qty.	Put this Ref. No. on the top of cover	Bid Type
1	To Establish the Network Facility/ICT at NIAB New Campus Detailed Specification mentioned below	As per NIT/Specification	NIAB/SP/2017-18/77	<u>SINGLE BID</u> <u>ONLINE</u>

TENDER EMD (REFUNDABLE)	Rs 100000 /-	Tenders without TENDER PROCESSING FEES / EMD (if applicable) will be rejected.
<u>TENDER PROCESSING CHARGES</u>	Rs 1500 /- (No exemption to any firm)	
<u>THIS FEES IS NOT EXEMPTED TO ANY FIRM & NON REFUNDABLE). (This is not tender fees/cost of NIT document as tender is issued free of cost, can be downloaded on CPPP / NIAB website or will be E mailed if asked from NIAB. All the firms want to participate this tender must submit this charges failing which your Bid will be rejected</u>	<u>All the firms want to participate in this tender must submit Rs 1500 as processing charges failing which your Bid will be rejected. Only EMD exemption is allowed as per chapter 4 -page no 8 of this NIT. For MSE /NSIC registered firms please read page no 8 of this NIT before claiming exemption (if any) for EMD only. Non Compliance/False information will result in rejection of Bid / Ban on Firm for future Tenders. (Rs 1500 /- No exemption to any firm, mandatory to submit the DD for all the firms)</u>	
MODE OF PAYMENT OF EMD/FEES	Demand Draft of any nationalized/commercial bank. <u>Please mention firm name & contact no, tender ref no backside of demand draft and Original DD must be sent to the NIAB HYDERABAD on or before Bid Submission Date & Time as mentioned in Critical Date Sheet.</u>	
DD IN FAVOUR OF	<u>National Institute of Animal Biotechnology</u> payable at Hyderabad.	
DD TO BE SUBMITTED TO	Manager (Stores & Purchase) National Institute of Animal Biotechnology (NIAB), D. No. 1-121/1, 5 th Floor, Axis Clinical Building, Opp. to Cine Town, Miyapur, Hyderabad, Telangana , India - 500 049	
The original EMD amount and Tender processing Fee in the form of Demand Draft towards cost of bid documents/processing shall be submitted to Manager (Store & Purchase) , NIAB by hand delivery/courier on or before the due date for submission of bids failing which the bid will be rejected. The reference no. of the Tender and super scribing the word “EMD and Tender Fee” should be specifically mentioned on the top of the envelope. Any catalogue /broacher /technical literature which is difficult to scan, except bid document is also permitted along with EMD. This document will be used only as extra supportive for information purpose and not mandatory for submission.		
PRE-BID MEETING (IF ANY)	26-03-2018 (At NIAB 5th floor of at 14.30 pm NIAB Miyapur adressed mentioned in page 1 of this document	
The objective of Pre-Bid Meeting is to provide a platform for clarifying issues and clearing doubts, if any, about the specification and other allied technical / commercial details of the bid document. This is also an opportunity to question the bidding conditions and the bidding process. Bids should be submitted only after the PBM if any so as to take care of the changes made in the bidding document. The prospective PBC participants should inform their intention to participate and send written queries at the email santosh@niab.org.in, spm@niab.org.in sufficient before PBC date to enable us to keep the response ready. The changes made to the bidding document subsequent to the PBM shall be treated as amendment to this bidding document and the same shall also be hosted on NIAB website.		
CRITICAL DATE SHEET (Please strictly adhere to the dates mentioned in this document.		
Tender Published Date	15-03-2018 (As per CPPP portal time)	
Bid Submission Start Date	15-03-2018 (As per CPPP portal time)	
Bid Submission End Date	05-04-2018 (at 14.00 hrs)	
Bid Opening Date	06-04-2018 (at 14.30 hrs)	
The bidders are requested to please note that all future amendments/corrigendum will be published on NIAB website and no separate advertisement will be released for the same. Bidders are therefore requested to regularly visit our website for any such updates.		

CHAPTER-2
INFORMATION TO BIDDERS -PART-1

1	Bids shall be submitted online only at CPPP website: https://eprocure.gov.in/eprocure/app .
2	<u>Please note the number of covers in which the bid documents have to be submitted, the number of documents including the names and content of each of the document that need to be submitted. Any deviations from these may lead to rejection of the bid. Please read Chapter -5 carefully and prepare all required form /Technical & Price Bid ready before starting the procedure.</u>
3	The bidders can enroll themselves on the website http://eprocure.gov.in using the option “Click here to Enroll”. Possession of a Valid Class II/III Digital Signature Certificate (DSC) in the form of smart card/e-token in the Company's name is a prerequisite for registration and participating in the bid submission activities through this web site. Digital Signature Certificates can be obtained from the authorized certifying agencies, details of which are available in the web site http://eprocure.gov.in under the link “Information about DSC”. The web site also has user manuals with detailed guidelines on enrolment and participation in the online bidding process. The user manuals can be downloaded for ready reference. Please visit website: - http://eprocure.gov.in/eprocure/app and get complete information.
4	Bid documents may be scanned with 100 dpi with black and white option which helps in reducing size of the scanned document.
5	The tenderers should have Digital Signature Certificate (DSC) for filling up the Bids. The person signing the tender documents should be authorized for submitting the on line e-tender.
6	Please go through the tender advertisement and the tender document carefully to understand the documents required to be submitted as part of the bid.
7	Bidder, in advance, should get ready the bid documents to be submitted as indicated in the tender document / schedule and generally, they can be in PDF / XLS / RAR / DWF/JPG formats. Bid documents may be scanned with 100 dpi with black and white option which helps in reducing size of the scanned document.
8	To avoid the time and effort required in uploading the same set of standard documents which are required to be submitted as a part of every bid, a provision of uploading such standard documents (e.g. PAN card copy, annual reports, auditor certificates etc.) has been provided to the bidders. Bidders can use “My Space” or “Other Important Documents” area available to them to upload such documents. These documents may be directly submitted from the “My Space” area while submitting a bid, and need not be uploaded again and again. This will lead to a reduction in the time required for bid submission process.
9	Upon the successful and timely submission of bids (i.e. after Clicking “Freeze Bid Submission” in the portal), the portal will give a successful bid submission message & a bid summary will be displayed with the bid no. and the date & time of submission of the bid with all other relevant details. The bid summary has to be printed and kept as an acknowledgement of the submission of the bid. This acknowledgement may be used as an entry pass for any future meetings.
10	Tenderer who has downloaded the tender from the Central Public Procurement Portal (CPPP) website https://eprocure.gov.in/eprocure/app and NIAB website shall not tamper/modify the tender form including downloaded price bid template, All other format in any manner. In case if the same is found to be tempered/ modified in any manner, tender will be completely rejected and EMD would be forfeited and tenderer is liable to be banned from doing business with NIAB
11	Please Make sure all format asked as per CHAPTER - 5 of tender document are properly uploaded online in suitable cover on CPPP Website for E-Procurement http://eprocure.gov.in .
12	Please read Point 15 & 16 of chapter -3 carefully to submit all supporting documents & give best discounted rates which can help you to get this contract.

CHAPTER – 3

INFORMATION TO BIDDERS -PART-2

SN	DETAILS
1	BIDDERS ELIGIBILITY / QUALIFICATION / REQUIREMENTS
	<p>This Invitation for Bids is open to all Original Manufacturers/ their Authorized Dealers/ vendors / suppliers to quote on their behalf for this tender as per Manufacturer’s Authorization Form and Indian Agents of Foreign Principals, if any who possess the qualifying requirements as specified in the Tender. Any person signing a Tender shall submit documentary evidence that his signature on the Tender, submitted by him, is legally binding upon himself, his firm. If it is detected that the person so signing the Tender has no authority to do so, the Director, NIAB may, without prejudice to other civil and criminal remedies, not consider the Tender and hold the signatory liable for all costs and damages. Bidders should not be associated, or have been associated in the past, directly or indirectly, with a firm or any of its affiliates which have been engaged by the Purchaser to provide consulting services for the preparation of the design, specifications, and other documents to be used for the procurement of the goods to be purchased under this Invitation of Bids. The bidder or his agent must have an office in India. That the Bidder will assume total responsibility for the fault-free operation of equipment, application software, if any, and maintenance during the warranty period and provide necessary maintenance services after end of warranty period if required. Bidders who meet the criteria given above are subject to be disqualified, if they have made untrue or false representation in the forms, statements and attachments submitted in proof of the qualification requirements or have a record of poor performance, not properly completing the contract, inordinate delays in completion or financial failure, etc. Other things being equal, preference shall be / may be given to firms who or his principal has supplied and installed similar system at any CSIR/ICAR/ICMR/DAE/DRDO/DST/DBT/other Govt. or autonomous research Labs in India. The Bidder should be a manufacturer or their dealer specifically authorized by the manufacturer to quote on their behalf of this tender as per manufacturer authorization form and Indian agents of foreign principals, if any who must have designed, manufactured, tested and supplied the equipment(s) similar to the type specified in the “Technical Specification”. Such equipment must be of the most recent series/models incorporating the latest improvements in design. The models should be in successful operation for at least one year as on date of Bid Opening in India and is engaged in R&D activities. The Indian Agents of foreign manufacturers / suppliers quoting directly on behalf of their principals for items appearing in the restricted list of the current Foreign Trade Policy must be registered with DGS&D. One Indian Agent cannot represent two different foreign principals for the same item in one tender. The bidder should have executed at least one similar order successfully during the preceding three financial years. Details of service support facilities that would be provided after the warranty period should be submitted in the Service Support Details Form. That, in the case of a Bidder not doing business in India, the Bidder is/or will be (if successful) represented by an Agent in India who shall be equipped and able to carry out the Supplier’s maintenance, repairs and spares parts.</p>
2	OPENING OF BIDS
	<p>In case of SINGLE BID system, the bid is required to be submitted in ONE PART. Techno-Commercial & Financial / Price Bid together as one single bid. In case of single bid system ---- Bids will be opened on the date and time given and technical evaluation committee will chose technically suitable and finically L1 bidder. All the process will be done online through E-PROCUREMENT UNDER CENTRAL PUBLIC PROCUREMENT PORTAL (eprocure.gov.in).</p> <p>In case of TWO BID system, the bid is required to be submitted in TWO PARTS. One part is the Technical Unpriced Bid (PART-I) and the other part is the Price / Financial Bid (PART-II). In two bid system -----In the first instance, the Technical Bids (PART-I) will be opened. Final selection of the Technical Bids will be based on the Technical Evaluation by the authorities of NIAB. The Price Bid of only those Technical Bid(s) are found technically suitable will be opened subsequently by informing to qualified vendors.</p>
3	LANGUAGE OF BID
	The bid prepared by the bidder, as well as all correspondence and documents relating to the bid exchanged by the bidder and the purchaser shall be written in Hindi/English language only.
4	DOCUMENTS COMPRISING THE TECHNICAL BID
	All necessary catalogues/technical literature, data as are considered essential for full and correct evaluation of offers, Please read points given in Chapter-5, for all forms, Declaration by the bidder that the goods are not in the restricted list of the current Indian EXIM Policy, DGS&D Registration certificate, if applicable. Details of Installations of similar equipment in India; Availability of number of trained support personnel, both application & service support. Compliance statement indicating yes/no as per the specifications.
5	BID PRICES
	Please read points given in Chapter No- 2 before preparing Price Bid /Quotation and submit the same along with PRICE SCHEDULE ‘A’ & PRICE SCHEDULE ‘B’ after considering all the points.
6	DOCUMENTS ESTABLISHING BIDDER’S ELIGIBILITY AND QUALIFICATIONS
	The bidder shall furnish, as part of its bid, documents establishing the bidders’ eligibility to bid and its qualification to perform the contract if its bid is accepted. That the bidder meets the qualification criteria as per Bid document. In case a bidder not doing business within the purchasers’ country, that the bidder is or will be represented by an agent in the country equipped and able to carry out the supply, maintenance, repair obligations etc. during the warranty and post-warranty period or ensure a mechanism at place for carrying out the supply, maintenance, repair obligations etc. during the warranty and post-warranty period.
7	DOCUMENTS ESTABLISHING GOOD’S ELIGIBILITY AND CONFORMITY TO BIDDING DOCUMENTS

	To establish the goods' eligibility, the documentary evidence of the goods and services eligibility shall consist of a statement on the country of origin of the goods and services offered which shall be confirmed by a certificate of origin at the time of shipment. To establish the conformity of the goods and services to the specifications, the documentary evidence of conformity of the goods and services to the bidding documents may be in the form of literature, drawings and data etc.
8	EARNEST MONEY DEPOSIT (EMD)/TENDER FEES (if any)
	The Bidder shall furnish, as part of its bid, Earnest Money Deposit (EMD) / TENDER FEES (if any) specified in the Bid document. This shall be submitted either by the principal or by the Indian agent and in the case of indigenous bidders shall be submitted by the manufacturer or their authorized dealer. The Bid Security is required to protect the Purchaser against the risk of Bidder's conduct, which would warrant the security's forfeiture. The Bid Security shall be in Indian Rupees for offers received for supply within India or freely convertible currency in the case of offers received for supplies from foreign countries. The Bid Security shall be payable promptly upon written demand by the purchaser in case the conditions in the Tender Documents are invoked. The Bid Security should be submitted in its original format. Copies shall not be accepted. The successful Bidder's Bid Security will be discharged upon the Bidder furnishing the performance security. The firms registered with DGS&D & NSIC, if any, are exempted from payment of EMD provided such registration includes the item they are offering which are manufactured by them and not for selling products manufactured by other companies. The bid security may be forfeited. If a Bidder withdraws or amends or impairs or derogates its bid during the period of bid validity specified by the Bidder; or In case of a successful Bidder, if the Bidder fails to furnish order acceptance within 15 days of the order and/or fails to furnish Performance Security within 21 days from the date of contract/ order.
9	PERIOD OF VALIDITY OF BIDS
	Bids shall remain valid for 180 days after the date of bid opening prescribed by the Purchaser
10	NEGOTIATIONS
	Negotiations, if any and at all done, shall be held with only the lowest technically Qualified evaluated responsive bidder.
11	PURCHASER'S RIGHT TO ACCEPT ANY BID AND TO REJECT ANY OR ALL BIDS
	The Purchaser reserves the right to accept or reject any bid, and to annul the bidding process and reject all bids at any time prior to award of Contract, without thereby incurring any liability to the affected Bidder or Bidders.
12	PURCHASER'S RIGHT TO VARY QUANTITY, ADD SPECIAL TERMS IF REQUIRED AT THE TIME OF AWARD OF
	The Purchaser reserves the right at the time of award of Contract to increase or decrease the quantity of goods and services originally specified in the Tender documents without any change in unit price or other terms and conditions. This tender document and all terms and conditions, Purchase order terms / special term if mutually agreed will be form parts of total contract.
13	JOINT VENTURE, CONSORTIUM OR ASSOCIATION
	If the Supplier is a joint venture, consortium, or association, all of the parties shall be jointly and severally liable to the Purchaser for the fulfilment of the provisions of the Contract and shall designate one party to act as a leader with authority to bind the joint venture, consortium, or association. The composition or the constitution of the joint venture, consortium, or association shall not be altered without the prior consent of the Purchaser.
14	DISQUALIFICATION OF TENDERS
	Tenders are liable for rejection if they are not in line with the terms and conditions of this tender notice. Conditional quotations will be liable for rejection or may not be considered. Incomplete tenders /tenders without EMD will be liable for rejection. Submission of Single Bid as against Two Bid System or Quotes submitted in Email/fax will be rejected. The Bidder should ensure that the prices are mentioned only in the Price Bid and nowhere in the Technical Bids in case of TWO BID SYSTEM.
15	PRELIMINARY EXAMINATION /EVALUATION & COMPARISON OF BIDS
	Technically Qualified L1 is main base point for award of contract. The Purchaser shall examine the bids to confirm that all documents and technical documentation requested in have been provided, required sureties have been furnished, and to determine the completeness of each document submitted. The Purchaser will examine the technical bids to determine whether they are complete, whether the documents have been properly signed, and whether the bids are generally in order. The competent committee decision and parameters will be final for qualifying the firms technically. No queries will be entertained for the decision and method for the same. No interim queries will be entertained till final award of contract. The total cost of requirement/item/service to be purchased is main criteria for evaluation irrespective of different standard warranty period offered in any. The purchase of Additional warranty /CMC is at sole discretion of institute and not mandatory for comparison in case of standard warranty period differs. For the bids surviving the technical evaluation which have been found to be responsive the evaluation & comparison shall be made as under: The final landing cost of purchase after all discounts, freight, forwarding, insurance warehouse to warehouse, custom clearing charges, all duties, taxes etc. shall be the basis of evaluation. Imported Vs. Indigenous Offers - The final landing cost (ware house to ware house) of purchase taking into account, freight, forwarding, insurance, taxes etc. CIF/CIP with customs clearance charges, Bank/LC charges, transportation up to NIAB, Hyderabad shall be the basis of evaluation. Conditional tenders/discounts etc. shall not be accepted. Rates quoted without attached conditions (viz. Discounts having linkages to quantity, payment terms etc.) will only be considered for evaluation purpose. Thus conditional discounted rates linked to quantities and prompt/advance payment etc. will be ignored for Comparison. The Purchaser however reserves the right to use the discounted rate/rates considered workable and appropriate for counter offer to the successful tenderers. Arithmetical errors in the financial bids will be rectified on the following basis. If there is a discrepancy between the unit price and the total price that is obtained by multiplying the unit price and quantity, the unit price shall prevail and the total price shall be corrected. If the supplier does not accept the correction of errors, its bid will be rejected. If there is a discrepancy between the price quoted in words and figures, the rate quoted in words will be taken as final and shall be binding on the Bidder. To facilitate evaluation and comparison, the Purchaser will convert all bid prices expressed in the amounts in various currencies in which the bid prices are payable to Indian Rupees at the selling exchange rate established by any bank in India as notified in the Newspaper / Bank Website on the date of Price Bid opening.

The competent authority at its discretion can use the following criteria/method to award the contract.

Technical Marking Points (A)

SN	Point	Description	Marks
1	Technical Specification	Technical Specification adherence as per bid submitted, Quality of Make /Material Quoted as per BID.	
2	Past Supply/work experience	Overall company profile Past supply , , Quality of past project completed, delivery schedule , completed contract , value of contract, Customer feedback , work done for Govt /Autonomous /semi Govt organization etc as assessed by committee constituted by competent authority.	
3	Company Profile	Technical expertise HR /service support of company, Project handling skills, professional membership , standards certification , Average/Annual turnover, financial strength & status, bank solvency of firm.etc	
4	Technical presentation	Layout, sample module, plan of work, Technical Presentation to committee about requirement /features of products/ plan /execution of work etc as required by NIAB.	
		Total	100
		Part A	60 % of Above total Marks

Considering above points, firms are informed to submit all relevant supporting documents which will give them better marks in above technical criteria.

Financial Marking Points (B)

The price Bid will be opened. Ranking will be done as L1 ,L2,L3,L4etc on total cost basis & L1 will be the lowest cost of all . Then L1 will be given 100 Marks. $L2 = (L1 \text{ cost} \times 100) / L2 \text{ cost}$. and like L3 , L4 marks will be calculated.

Part -B 40 % of Above total Marks

Total Marks = Part -A+ Part -B mentioned as above will be calculated.
Firm getting highest marks (Part -A+ Part -B) will get contract

16 **The decision of competent authority & concerned committee of NIAB will be final about the process of evaluation and award of contract and no claim whatsoever will be entertained in this regards. Considering above points, firms are informed to submit all relevant supporting documents which will give them better marks in above technical criteria. Please Quote best discounted price. This will be helping the firm in getting this contract.**

MSE Guidelines for EMD/Tender Fees Exemption

Registration of Micro, Small and Medium Enterprises for two types of Companies:

Manufacturing Entity : -- The enterprises engaged in the manufacture or production of goods pertaining to any industry specified in the first schedule to the industries (Development and regulation) Act, 1951). The Manufacturing Enterprise are defined in terms of investment in Plant & Machinery.

Service Entity : -- The enterprises engaged in providing or rendering of services and are defined in terms of investment in equipment.

No.	Type of Enterprise	Manufacturing Enterprises (Investment in Plant and Machinery)	Service Industry (Investment in equipment)
1.	Micro	Does not exceed Rs. 25 Lakh	Does not exceed Rs. 10 Lakh
2.	Small	Exceeds Rs. 25 Lakh but does not exceed Rs. 5 Crore	Exceeds Rs. 10 Lakh but does not exceed Rs. 2 Crore
3.	Medium	Exceeds Rs. 5 Crore but does not exceed Rs. 10 Crore	Exceeds Rs. 2 Crore but does not exceed Rs. 5 Crore

Presently EMD/Tender Fee exemptions and price preference are applicable to only Micro and Small Industries. View above, if you are claiming EMD/Tender Fee exemptions, you should meet above criteria for Micro and Small Industries.

- 1 You have to submit your supporting documents issued by competent Govt bodies to become eligible for the above exemption.
- 2 Also your certificate (NSIC) / MSE shall cover the items tendered to get EMD/Tender fee exemptions.
- 3 NSIC certificate shall be valid as on due date / extended due date of the tender.
- 4 In case the bid is submitted as an Indian arm of a foreign bidder and the eligibility criteria conditions were met thru foreign company, then the EMD Exemption cannot be claimed under the MSME status of Indian arm / subsidiary.

Thus a Bidder who solely on it's own, fulfills each eligibility criteria condition as per the tender terms and conditions and who are having MSE status, can claim EMD exemption/ tender fee.

If all these conditions are not fulfilled or supporting documents are not submitted with the Bid , then all those Bids without Tender fees /EMD will be summarily rejected and no queries will be entertained.

TENDER PROCESSING CHARGES Rs 1500 /- is mandatory for all firms and not exempted to any firm. This Tender document is free of cost and no tender fees is applicable. EMD exemption is as rules mentioned herein.

Please read following points before preparing Price Bid /Quotation and submit your price bid including PRICE SCHEDULE 'A' & PRICE SCHEDULE 'B' after considering all the points.

SN	Point	Description	Point Noted & complied in Price Bid.
			Mark ✓
1	Price Breakup	<p>The Bidder shall indicate the unit prices, discounts rate / percentage and total bid prices of the goods it proposes to supply. All breaks up of price incl Packing, Transportation, Taxes, incidental expenses must be given up to satisfactory installation in NIAB premise.</p> <p>Vague terms like “packing, forwarding, transportation, taxes etc. extra” without mentioning the specific amount/percentage of these charges will NOT be accepted. Where there is no mention of packing, forwarding, freight, insurance charges, such offers shall be summarily rejected as incomplete / non-responsive.</p> <p>Prices quoted by the bidder shall remain fixed during the entire period of contract and shall not be subject to variation on any account.</p>	<input type="checkbox"/> Point Noted for Bid Preparation
2	Quote for Complete item set up / functioning required as per specification.	Item quoted should be complete in all respects; any additional accessories required for instrument to operate /function should also be quoted as part of the instrument and should be supplied along with instrument. It should not be included in optional.	<input type="checkbox"/> Point Noted for Bid Preparation
3	Optional accessories / PC /UPS /stabilizer	The cost of accessories in optional should be quoted separately. List of all optional accessories with detail specification must be given with List price & discount.	<input type="checkbox"/> Point Noted for Bid Preparation
4	Bid Currencies	Prices shall be quoted in Indian Rupees or in freely convertible foreign currency preferably in USD (\$), Euro (€), Yen (¥), GBP (£) wherever possible for correct evaluation during comparison.	<input type="checkbox"/> Point Noted for Bid Preparation
5	For indigenous Items OR goods of foreign origin to be supplied in Indian currency	<p>Ex-factory / Ex-warehouse //Ex-showroom /Off-the shelf</p> <p>Tax (if any) [%age & value]</p> <p>Transportation , loading/ unloading and incidental costs till NIAB site Insurance charges (if any with period cover)</p> <p>Incidental services (including installation & commissioning, and training) at NIAB site</p>	<input type="checkbox"/> Point Noted for Bid Preparation
6	Taxes, Custom duties etc.	<p>NIAB is exempted from payment of Excise Duty if any under notification number 10/97 dated 01.03.1997 and Customs Duty under notification No.51/96 dated 23.07.1996. Hence Excise Duty and Customs Duty, if any, should be shown separately. Please mention the applicable taxes clearly. We don't issue any 'Form C' or 'Form D'. Custom bonded warehouse price should be quoted in case of imported item quoting INR. Instrument quoted should be complete in all respects. If there is no explicit mention about taxes in your offer, then quoted price will be deemed inclusive of all such taxes and no other charges except those mentioned clearly in the quotation will be paid.</p> <p><u>The GST Rates / Exemption applicable will be as per GOI, MoF Notification No. 45 & 47/2017- (GST Rate) dt. 14/11/2017 & GOI - GST Law 2017 as applicable. The Custom duty Rates / Exemption will be as applicable as per Govt. of India Rules as applicable to DSIR Registered institute/Govt. funded research institute. It is certified that National Institute of Animal Biotechnology, is an Autonomous Institute of the Department of Biotechnology, Ministry of Science & Technology, Govt. of India and it is registered with the (DSIR) Department of Scientific & Industrial Research, Government of India vide their Registration No. TUY/RG-CDE(1175)/2015 dated 19th Aug 2015 . Valid up to 31.08.2020. It is also certified that the material/goods purchased for the institute is required for Research Programme in NIAB & used for conducting/support RESEARCH PURPOSE only.</u></p>	<input type="checkbox"/> Point Noted for Bid Preparation
7	Bid Validity	The Bid should be valid for at least 180 days.	

			<input type="checkbox"/> Point Noted for Bid Preparation
8	Comprehensive WARRANTY & AMC	<p>The charges for Annual CMC after warranty shall be quoted separately as per price schedule 'B'.</p> <p>Standard Warranty period is taken as 12 Months unless otherwise specified.</p> <p>Please quote for Extra Warranty After completion of standard warranty period.</p> <p><u>The purchase of Additional warranty /CMC is at sole discretion of institute.</u></p> <ul style="list-style-type: none"> ➤ The cost of Annual Maintenance Contract (AMC) which includes preventive maintenance including testing & calibration as per technical/service/ operational manual and labour, after satisfactory completion of warranty period may be quoted for next 3 (or as specified) years on yearly basis for complete equipment. ➤ The cost of CMC may be quoted along with taxes applicable on the date of Tender opening. The taxes to be paid extra, to be specifically stated. In the absence of any such stipulation the price will be taken inclusive of such taxes and no claim for the same will be entertained later. ➤ Cost of CMC will be added for ranking/evaluation purpose. ➤ The uptime warranty will be 98% on 24 (hrs) x 7 (days) x 365 (days) basis. ➤ The stipulation in technical specification will supersede above provision. ➤ The supplier shall keep sufficient stock of spares required during comprehensive maintenance contract period. In case the spares are required to be imported, it would be the responsibility of the supplier to import and get them custom cleared and pay all necessary duties. 	<input type="checkbox"/> Point Noted for Bid Preparation
9	For Imported items	<p>Price can be Quoted in following terms FOB price at sea/airport of Lading Insurance (Warehouse to warehouse basis) Freight CIP by Air/Sea at the port of Entry (Hyderabad) If possible DDP value may please be quoted with consideration of Custom Duty amount as % of Net CIP (amount with CDEC as applicable) & Custom Clearance & Handling charges, incidental charges till satisfactory installation up to NIAB.</p> <p>The purchaser can place the order on FOB/ CIP or DDP basis. Export Packing, Loading Charges, and Inland Freight etc. In the shipper country will have to be paid by the Supplier. The Price for inland transportation, insurance and other local costs incidental to delivery of the goods up to their port of dispatch to be payable by the Supplier. Items as per the Purchase Order duly cleared for export in shipping country would be required to be handed over to our nominated freight forwarder in case of FOB order. The quoted price shall be deemed to include all taxes and duties/fee etc that will have to be paid in the country of origin/export by the bidder. Items are to be Packed, Marked & Labelled as per international norms. Small individual boxes must be palletized for easy handling & movement. State packing/ forwarding/ documentation charges etc. (each one) separately, if applicable. CIF/CIP rates for shipping items up to Hyderabad (India) preferably through AIR INDIA should also be mentioned. Even if the order is placed on CIF/CIP basis, bidder will have to only use the services of our nominated freight forwarding agent for the sake of operational convenience at the time of customs clearance at our end. This condition will be mandatory.</p>	<input type="checkbox"/> Point Noted for Bid Preparation
<p><u>Please read above points before preparing Price Bid /Quotation and submit your quotation after carefully reading /considering all the points.</u></p>			

CHAPTER 4**GENERAL CONDITIONS OF CONTRACT.**

SN	DETAILS
1	DEFINITIONS
	<p>In this Contract, procurement through this tender ,the following terms shall be interpreted as indicated: The following words and expressions shall have the meanings hereby assigned to them:</p> <p>“Contract Price” means the price payable to the Supplier as specified in the Purchase Order, subject to such additions and adjustments thereto or deductions there from, as may be made pursuant to the Contract. “Day” means calendar day. “Completion” means the fulfilment of the Related Services by the Supplier in accordance with the terms and conditions set forth in the Purchase Order. “Goods” means all of the commodities, raw material, machinery and equipment, and/or other materials that the Supplier is required to supply to the Purchaser as per the Purchase Order. “Related Services” means the services incidental to the supply of the goods, such as transportation, insurance, installation, commissioning, training and initial maintenance and other such obligations of the Supplier as per the Purchase Order. “Supplier” means the natural person, private or government entity, or a combination of the above, whose bid to perform the Contract has been accepted by the Purchaser and is named as such in the Purchase Order. The final destination,” where applicable, means the place of delivery as indicated in the Purchase Order. “The Purchaser” is ‘The Director, National Institute of Animal Biotechnology (N.I.A.B), Hyderabad, Telangana. “The Purchaser’s country is “India”.</p>
2	SUPPLIER’S RESPONSIBILITIES
	The Supplier shall supply all the Goods and Related Services included in the Scope of Supply and the Delivery and Completion Schedule, as per Purchase Order Terms.
3	SUB-CONTRACTS
	The Supplier shall notify the Purchaser in writing of all subcontracts awarded under this Contract if not already specified in the bid. Such notification, in his original bid or later, shall not relieve the Supplier from any liability or obligation under the Contract. Sub-contract shall be only for bought-out items and sub-assemblies. The Supplier shall not assign, in whole or in part, its obligations to perform under the Contract, except with the Purchaser's prior written consent
4	CONTRACT PRICE
	Prices charged by the Supplier for the Goods supplied and the Related Services performed under the Purchase Order shall not vary from the prices quoted by the Supplier in its bid.
5	COPY RIGHT
	The copyright in all drawings, documents, and other materials containing data and information furnished to the Purchaser by the Supplier herein shall remain vested in the Supplier, or, if they are furnished to the Purchaser directly or through the Supplier by any third party, including suppliers of materials, the copyright in such materials shall remain vested in such third party
6	PATENT RIGHTS
	The Supplier shall indemnify the Purchaser against all third-party claims if any, of infringement of patent, trademark or industrial design rights, copy rights arising from use of the Goods or any part thereof in India.
7	INSPECTIONS AND TEST
	The Supplier shall at its own expense and at no cost to the Purchaser carry out all such tests and/or inspections of the Goods and Related Services Or as discussed during the course of finalizing the contract. The Purchaser or its representative shall have the right to inspect and/or to test the Goods to confirm their conformity to the Contract specifications at no extra cost to the Purchaser. The Purchaser shall notify the Supplier in writing in a timely manner of the identity of any representatives retained for these purposes. The inspections and tests may be conducted on the premises of the Supplier or its subcontractor(s), at the point of delivery and/or at the Goods final destination. If conducted on the premises of the Supplier or its subcontractor(s), all reasonable facilities and assistance, including access to drawings and production data -shall be furnished to the inspectors at no charge to the Purchaser.
8	PACKING
	<p>The Supplier shall provide such packing of the Goods as is required to prevent their damage or deterioration during transit to their final destination. The packing shall be sufficient to withstand, without limitation, rough handling during transit and exposure to extreme temperatures, salt and precipitation during transit and open storage. Packing case size and weights shall take into consideration, where appropriate, the remoteness of the Goods' final destination and the absence of heavy handling facilities at all points in transit. In order to maintain safety of the equipment, we prefer to have wooden crating with adequate cushion inside for transportation of any goods. The Material to be dispatched with International standard packing to withstand Rigors, and to avoid any transit damages.</p> <p>PACKING INSTRUCTIONS</p> <p>Each package will be marked on three sides with proper paint/indelible ink, the following: Purchaser Name & Address, Item Nomenclature, Order/Contract No. ,Country of Origin of Goods ,Packing list reference number</p>
9	AMENDMENTS
	The Purchaser may at any time, by written order given to the Supplier make changes within the general scope of the Contract as mutually agreed terms.
10	DELIVERY AND DOCUMENTS
	Delivery of the Goods and completion related services shall be made by the Supplier in accordance with the terms specified by the Purchaser in the Purchase Order/Maximum within 08 weeks.

	<p>Delivery of the Goods shall be made by the Supplier in accordance with the terms specified by the Purchaser in the Purchase Order. The details of shipping and / or other documents to be furnished by the supplier are also specified in Purchase Order. Delivery of the goods should be made as per the Delivery Schedule incorporated in the Purchase Order. The supplier should intimate the shipment details within 72 hours before for custom clearance of the material.</p> <p>The supplier shall notify the purchaser the full details of the shipment including order/contract number, railway receipt number /AWB etc and date, description of goods, quantity, name of the consignee, invoice etc. The supplier shall e-mail the following documents to the purchaser, with a copy to the Clearing Agent.</p> <ol style="list-style-type: none"> i. 3 copies of the Supplier invoice showing Order/contract number, goods' description, quantity, unit price, total amount; ii. Acknowledgement of receipt of goods from the consignee(s) by the transporter; iii. Insurance Certificate if applicable; iv. Manufacturer's/Supplier's warranty certificate; v. Inspection Certificate issued by the nominated inspection agency, if any, and the Supplier's factory inspection report; a vi. Certificate of Origin. vii. Two copies of the packing list identifying the contents of each package. viii. Airway Bill / Bill of Lading <p>The above documents should be received by the Purchaser before arrival of the Goods (except where the Goods have been delivered directly to the Consignee with all documents) and, if not received, the Supplier will be responsible for any consequent expenses.</p> <p>Please make appropriate commitments in writing that the instrument model being offered is current and is not likely to be obsolete within the next couple of years and that spare parts will be available for it for at least seven years after the installation. The Installation of the equipment is deemed complete only after all the sub-units of the main equipment such as the computers/printers/UPS/Software etc., is installed and tested as per the specifications in the offer/brochure / purchase order and demonstrated to the satisfaction of the end user.</p>
11	INSURANCE
	<p>The Goods supplied under the Contract shall be fully insured in Indian Rupees against loss or damage incidental to manufacture or acquisition, transportation, storage and delivery. For delivery of goods at the purchaser's premises, the insurance shall be obtained by the Supplier in an amount equal to 110% of the value of the goods from "Warehouse to warehouse" (final destinations) on "All Risks" basis including war Risks and Strikes. The insurance shall be valid for a period of not less than 3 months after installation and commissioning. However, in case of orders placed on FOB/FCA basis, the purchaser shall arrange insurance.</p>
12	TRANSPORTATION
	<p>Where the Supplier is required under the Contract to deliver the Goods on FOB, transport of the Goods, up to and including the point of putting the Goods on board the vessel at the specified port of loading, shall be arranged and paid for by the Supplier. Where the Supplier is required under the Contract to deliver the Goods FCA, transport of the Goods and delivery into the custody of the carrier at the place named by the Purchaser or other agreed point shall be arranged and paid for by the Supplier, and the cost thereof may be included in the Price Schedules. Where the Supplier is required under the Contract to deliver the Goods CIF or CIP, transport of the Goods to the port of destination or such other named place of destination in the Purchaser's country, as shall be specified in the Contract, shall be arranged and paid for by the Supplier, and the cost thereof maybe included in the Price Schedules. In the case of supplies from within India, where the Supplier is required under the Contract to transport the Goods to a specified destination in India, defined as the Final Destination, transport to such destination, including insurance and storage, shall be arranged by the Supplier, and the related costs may be included in the Contract Price.</p>
13	STANDARDS
	<p>The Goods supplied and services rendered under this Contract shall conform to the standards mentioned in the Technical Specifications, and, when no applicable standard is mentioned, to the authoritative standard appropriate to the Goods' country of origin and such standards shall be the latest issued by the concerned institution</p>
14	WARRANTY
	<p>The Supplier warrants that all the Goods are new, unused, and of the most recent or current models, and that they incorporate all recent improvements in design and materials, unless provided otherwise in the Contract.</p> <p>The Warrantee should be comprehensive and on site. The Supplier further warrants that the Goods shall be free from defects arising from any act or omission of the Supplier or arising from design, materials, and workmanship, under normal use in the conditions prevailing in India.</p> <p>The warranty shall remain valid for twelve (12) months from the date of installation of the equipment or as per the Specification whichever is higher. The Purchaser shall give notice to the Supplier stating the nature of any such defects together with all available evidence thereof, promptly following the discovery thereof. The Purchaser shall afford all reasonable opportunity for the Supplier to inspect such defects. Upon receipt of such notice, the Supplier shall, within a reasonable period of time expeditiously repair or replace the defective Goods or parts thereof, at no cost to the Purchaser. If during the period of warranty any component or spare part is need to be brought from abroad, all associated cost shall be borne by the supplier including the cost of customs duty.</p> <p>All incidental charges / additional duties incurred for importing warrantee replacements are to be borne by the suppliers. The defective material / goods will not be handed over to the supplier and the same will be re-exported to the place of manufacturer at the cost of the supplier. In case, the manufacturer has the office in India the same may be handed over to them with an undertaking that they will re-export to their manufacturing facility within a reasonable time and submit the proof to that extent.</p> <p>If having been notified, the Supplier fails to remedy the defect within a reasonable period of time; the Purchaser may proceed to take within a reasonable period such remedial action as may be necessary, at the Supplier's risk and expense and without prejudice to any other rights which the Purchaser may have against the Supplier under the Contract.</p>

15	TERMS OF PAYMENT
	<p>Payment Term will be finalized by NIAB Policy and remain mandatory for supplier as issued in Contract /Purchase order. Our rules do not permit any advance payment either direct or through a bank. However, payment of your bill will be made after receipt of the articles in good condition & successful installation by way of DEMAND DRAFT / Foreign Demand Draft (FDD)/LC or Wire Transfer as per NIAB Order Terms & conditions.</p> <p>For Indigenous items Payment will be made after delivery and installation. For service contract /work order Payment will be made 90 % after delivery and installation. 10 % after submission of bank guarantee for warranty period.</p> <p>All banking charges outside India will be borne by the supplier and inside India charges will be borne by the purchaser. Commercial Invoice produced by Reprographic system or automated computerized system marked as original not acceptable. The following documents shall be required by the Purchaser for payment. Signed commercial invoice in quadruplicate, Certificate of Origin issued by the Beneficiary/ Concerned Chamber of Commerce, Insurance copies/ certificates, Airway Bill / Bill of Lading Copy, Packing list indicating description of goods and quantity package wise in triplicate.</p>
16	EXTENSION OF TIME
	<p>Delivery of the Goods and performance of the Services shall be made by the Supplier in accordance with the time schedule specified in the contract. If at any time during performance of the Contract, the Supplier or its sub-contractor(s) should encounter conditions impeding timely delivery of the Goods and performance of Services, the Supplier shall promptly notify the Purchaser in writing of the fact of the delay, its likely duration and its cause(s). As soon as practicable after receipt of the Supplier's notice, the Purchaser shall evaluate the situation and may, at its discretion, extend the Supplier's time for performance with or without penalty, in which case the extension shall be ratified by the parties by amendment of the Contract.</p> <p>Except as provided under the Force Majeure clause, a delay by the Supplier in the performance of its delivery obligations shall render the Supplier liable to the imposition of penalty pursuant to Penalty Clause unless an extension of time is agreed upon pursuant to above clause without the application of penalty clause.</p>
17	PENALTY CLAUSE
	<p>Subject to clause on Force Majeure, if the Supplier fails to deliver any or all of the Goods or to perform the Services within the period(s) specified in the Purchase order, the Purchaser shall, without prejudice to its other remedies under the Contract, deduct from the Contract Price, as penalty, a sum equivalent to 1 percent of the order value for each week or part thereof of delay until actual delivery or performance, up to a maximum deduction of 10 Percent. Once the maximum is reached, the Purchaser may consider termination of the Contract for Default</p>
18	TERMINATION FOR DEFAULT / INSOLVENCY
	<p>The Purchaser may, without prejudice to any other remedy for breach of contract, by written notice of default sent to the Supplier, terminate the Contract in whole or part</p> <p>If the Supplier fails to deliver any or all of the Goods within the period(s) specified in the contract, or within any extension thereof granted by the Purchaser If the Supplier fails to perform any other obligation(s) under the Contract. If the Supplier, in the judgment of the Purchaser has engaged in corrupt or fraudulent or collusive or coercive practices.</p> <p>In the event the purchaser terminates the contract in whole or in part, he may take recourse to any one or more of the following action: The Performance Security is to be forfeited.</p> <p>The purchaser may procure, upon such terms and in such manner as it deems appropriate, stores similar to those undelivered, and the supplier shall be liable for all available actions against it in terms of the contract. The Purchaser may at any time terminate the Contract by giving written notice to the Supplier, if the Supplier becomes bankrupt or otherwise insolvent. In this event, termination will be without compensation to the Supplier, provided that such termination will not prejudice or affect any right of action or remedy, which has accrued or will accrue thereafter to the Purchaser.</p>
19	NOTICES
	<p>Any notice given by one party to the other pursuant to this contract/order shall be sent to the other party in writing and confirmed to the other party's address specified in the Purchase Order.</p>
20	SITE PREPARATION AND INSTALLATION
	<p>The supplier shall inform the purchaser about the site preparation, if any, needed for installation, of the goods at the purchaser's site immediately after placement of Purchase Order. In compliance with the technical and environmental specifications Supplier to perform a site inspection to verify the appropriateness of the sites before the installation of the equipment, if required.</p>
21	TAXES AND DUTIES
	<p>Suppliers shall be entirely responsible for all taxes, duties, license fees, octroi, road permits, etc., incurred until delivery of the ordered Goods to the Purchaser at the final destination. However, VAT in respect of the transaction between the Purchaser and the Supplier shall be payable extra, if so stipulated in order.</p>
22	INCIDENTAL SERVICES
	<p>The supplier may be required to provide any or all of the services, as discussed during the course of finalizing the contract. User and detailed Service Manual /training to be supplied along with the equipment.</p>
23	SPARE PARTS
	<p>The Supplier shall be required to provide the spare part details/materials, notifications, and information pertaining to its manufacture or distribution: Such spare parts as the Purchaser may elect to purchase from the Supplier, providing that this election shall not relieve the Supplier of any warranty obligations under the Contract; and In the event of termination of production of the spare parts: advance notification</p>

	to the Purchaser of the pending termination, in sufficient time to permit the Purchaser to procure needed Requirements if any; and Following such termination, furnishing at no cost to the Purchaser, the blueprints, drawings and specifications of the spare parts, if requested.
24	PERFORMANCE SECURITY
	<p>The successful Bidder must be ready to provide Performance security (10% of the order value unless mentioned otherwise) in the Performance Security Form provided in the Bid Document, within 21 days of the receipt of notification of award/purchase order from the Purchaser or/as mentioned in purchase order/contract awarded failing which it shall be presumed that the vendor is not interested and his bid security is liable to be forfeited & the contract shall be deemed terminated. The proceeds of the performance security shall be payable to the Purchaser as compensation for any loss resulting from the Supplier's failure to complete its obligations under the Contract.</p> <p>The Performance Security shall be submitted in one of the following forms:</p> <p>(i) Indian manufacturers/suppliers or Authorized Indian Agents of the Foreign Principals can submit the performance security on behalf of their foreign principals in the form of Bank Guarantee issued by a Nationalized/Scheduled bank located in India on the format provided in the bidding documents. OR</p> <p>(ii) Foreign Principals can also submit performance security directly on the prescribed format through any foreign or Indian bank having office preferably in Hyderabad (India) or in the form of Standby Letter of Credit which must be advised and confirmed by any bank in India located preferably in Hyderabad.</p> <p>The performance security/Standby LC will be discharged by the Purchaser and returned to the Supplier not later than 60 days following the date of completion of the Supplier's performance obligations, including any warranty obligations, unless specified otherwise. In the event of any contract amendment, the supplier shall, within 21 days of receipt of such amendment, furnish the amendment to the performance security/SLC, rendering the same valid for the duration of the contract, as amended for further period of 60 days thereafter.</p>
25	FRAUD AND CORRUPTION
	<p>The purchaser requires that the bidder's suppliers and contractors observe the highest standard of ethics during the procurement and execution of such contracts. In pursuit of this policy, the following are defined:</p> <p>“Corrupt practice” means the offering, giving, receiving, or soliciting, directly or indirectly, of anything of value to influence the action of a public official in the procurement process or in contract execution; “Fraudulent practice” means a misrepresentation or omission of facts in order to influence a procurement process or the execution of a contract; “Collusive practice” means a scheme or arrangement between two or more bidders, with or without the knowledge of the purchaser, designed to establish bid prices at artificial, non-competitive levels; and “Coercive practice” means harming or threatening to harm, directly or indirectly, persons or their property to influence their participation in the procurement process or affect the execution of a contract. The purchaser will reject a proposal for award if it determines that the Bidder recommended for award has, directly or through an agent, engaged in corrupt, fraudulent, collusive or coercive practices in competing for the Contract in question.</p>
26	SETTLEMENT OF DISPUTES
	<p>The Purchaser and the supplier shall make every effort to resolve amicably by direct informal negotiation any disagreement or dispute arising between them under or in connection with the Contract. If, after thirty (30) days from the commencement of such informal negotiations, the Purchaser and the Supplier have been unable to resolve amicably a Contract dispute, either party may require that the dispute be referred for resolution to the formal mechanisms. These mechanisms may include, but are not limited to, conciliation mediated by a third party, adjudication in an agreed national or international forum, and national or international arbitration. In case of Dispute or difference arising between the Purchaser and a domestic supplier relating to any matter arising out of or connected with this agreement, such disputes or difference shall be settled in accordance with the Indian Arbitration & Conciliation Act, 1996, the rules there under and any statutory modifications or re-enactments thereof shall apply to the arbitration proceedings. The dispute shall be referred to the Director, NIAB and if he is unable or unwilling to act, to the sole arbitrator so appointed shall be final conclusive and binding on all parties to this order. In the case of a dispute between the purchaser and a Foreign Supplier, the dispute shall be settled by arbitration in accordance with provision of sub-clause (a) above. But if this is not acceptable to the supplier then the dispute shall be settled in accordance with provisions of UNCITRAL (United Nations Commission on International Trade Law) Arbitration Rules. The Venue of the arbitration shall be the place from where the order is issued.</p>
27	APPLICABLE LAW
	<p>The Contract shall be interpreted in accordance with the laws of the Union of India and all disputes shall be subject to place of jurisdiction Hyderabad.</p>

CHAPTER - 5

REQUIRED DOCUMENTS/ FORMAT WITH BID (TO BE UPLOADED ONLINE)

(VERY IMPORTANT)

FORMAT TO KEEP READY BEFORE ONLINE SUBMISSION OF BIDS

Bid will contain all the technical details of the products along with following format. Please keep all the following documents ready in .pdf format printed on your company/firm letterhead for uploading on the website during online submission of your bid. Non Submission of these format may result in rejection of your bid. Read all forms carefully and submit it exactly same as per below format. Changing of our wording of format may result in rejection of your bids. You can type this or hand written forms are also accepted to be printed on firm letterhead.

IT IS SINGLE BID --- THERE IS ONLY COVER -1 --- FEE/PRE QUAL/TECHNICAL/FINANCE
It consist one part as follows. Keep this 1-6 documents scanned as only one pdf file ready for upload
before start applying for tender

Part-1 (Fees/Technical/Financial /Other Forms) (All 1-6 documents, as one pdf. File)

(All this document 1-6 scanned together as only one pdf file.)

Keep this 1-6 documents scanned as only one pdf file ready for upload before start applying for tender.

- 1. QUOTATION ON YOUR LETTERHEAD, FORMAT OF PRICE BID - PRICE SCHEDULE 'A' & PRICE SCHEDULE 'B' (If any) / FINANCIAL BID / SCANNED QUOTATION ON FIRM LETTERHEAD GIVING TOTAL COST OF REQUIRMENT IN TENDER AS PER CHAPTER NO 5.**
- 2. SCAN COPY OF DD (EMD /TENDER FEES AS APPLICABLE.)**
- 3. TECHNICAL BID COMPLIANCE FORM & TECHNICAL DESCRIPTION / LITERATURE/CATALOGUE etc AS PER THIS DOCUMENT CHAPTER NO 5 &6.**
- 4. ALL FORMS AS PER THIS DOCUMENT CHAPTER NO 5 &6.**
- 5. Copy of PAN card/ Certificate of Registration with Govt. Tax Authorities /GST / Income Tax returns for the last two Assessment Year as per current date. / Turnover Certificate of Last 02 years/As Per Tender.**
- 6. (If applicable) Copy of Registration Certificate issued by NSIC, Govt. of India Enterprise/DG, S&D / MSME, units registered with District Industries Centre / Joint Director of Commerce and Industries, Govt. of Telangana/ respective State Govts. With current validity / MSE / MSEs owned by SC/ST entrepreneurs in respect of those who are seeking exemption for payment of Earnest Money Deposit (Bid Security)/fees.**

Keep this 1-6 documents scanned as only one pdf file ready for upload before start applying for tender

FORM NO - 1

PROCESS COMPLIANCE/ACCEPTANCE OF TENDER CONDITIONS FORM

The Director,
National Institute of Animal Biotechnology (NIAB),
D. No. 1-121/1, 4th & 5th Floors, Axis Clinicals Building,
Miyapur, Hyderabad, Telangana, India - 500 049

Sub: Acceptance to the Process related & Terms and Conditions for the e-Tendering
Ref.:- The Terms & Conditions for e-Tendering mentioned in tender
No.: _____

Sir,

We hereby confirm the following.

The undersigned is authorized representative of the company. We have carefully gone through the NIT, Tender Documents and the Rules governing the e-tendering as well as this document. We have examined and have no reservations to the Bidding Documents, including addendum (if any). We offer to supply in conformity with the Bidding Documents and in accordance with the condition of contract, specified in this tender document. We will honour the Bid submitted by us during the e-tendering. We give undertaking that if any mistake occurs while submitting the bid from our side, we will honour the same.

Bid securing declaration:- We accept that if we withdraw or modify Bids during the period of validity, or if we are awarded the contract and fail to sign the contract, or to submit a performance security before the deadline defined in this bids document, we will be suspended for the period of 01 year from being eligible to submit Bids for contracts with NIAB.

We are aware that if NIAB has to carry out e-tender again due to our mistake, NIAB has the right to disqualify us for this tender. We confirm that NIAB shall not be liable & responsible in any manner whatsoever for my/our failure to access & submit offer on the e-tendering site due to loss of internet connectivity, electricity failure, virus attack, problems with the PC, digital signature certificate or any other unforeseen circumstances etc. Our bid shall be valid for the period from the date fixed for the bid submission deadline, and it shall remain binding upon us and accepted at any time before the expiration of bid validity period as per this tender.

If our bid is accepted, we commit to provide a performance security in Bank Guarantee /Fixed Deposits for due performance of the contract as per NIAB policy and warranty-guarantee as per tender specification or agrees as per contract. We understand that this bid, together with your written acceptance thereof included in your notification of award/placement of order, shall constitute a binding contract between us. We understand that you are not bound to accept the lowest evaluated bid or any other bid that you may receive. We accept that the competent authority in NIAB will have full right to reject any/all offer(s) without assigning any reason thereof and does not bind itself to accept the lowest or any other tender and full authority to postpone the tender issue date, submission /opening date or to alter any other condition of tender /cancellation of this tender, as per policy/committee recommendations of NIAB at any stage without assigning any reason thereof for which no claim from whomsoever will be entertained. I/We the undersigned, have read the entire terms and conditions of this Tender document and we are fully agreeable to the terms and conditions mentioned herein. The decision of competent authority of NIAB with respect to this Tender-Result will be fully agreeable and binding on us.

This letter can be treated as signed and acceptance copy of tender documents and the forms submitted as signed by competent authority of firm submitting this tender and there is no need to submit separate signed copy of tender document.

Competent Authority to sign:

Name:-

Designation:-

Contact Details :-

Date with stamp & seal of organization:

(FORM NO 2)
DETAILS OF LOCAL / ANY OTHER SERVICE SUPPORT

Location /Address of Service Centre :-

Name of Technical /In charge Person/Qualification :-

Phone/Fax/Email :-

Office Hours :-

Details of Service Facilities available :-

(FORM NO 3)
PRICE REASONABILITY CERTIFICATE

This is to certify that we have offered the maximum possible discounted price to your institute for the Item required as per this Tender No _____ in our Quotation No. _____ date _____ for total Currency / as per quotation submitted .We would like to certify that the quoted price are the minimum and we have not quoted the same item on lesser rates than those being offered to NIAB to any other customer nor we will do so till the validity of offer or execution of purchase order, whichever is later.

(FORM NO 4)
PERFORMANCE STATEMENT/ CLIENTELE/LIST OF USER

Attached separate sheet in same format if above place is not sufficient

Please find attached herewith our list of clients to whom we have supplied the same /similar equipment as required vide this Tender No _____ dt _____ for the item _____

SN	Name & Address of purchaser	Description and quantity of ordered equipment	Order No. and date	Date of delivery	Contact Person along with Tel. NO., Fax No. & e-mail address

(FORM NO.5)
MANUFACTURERS' AUTHORIZATION

Note: This letter of authority should be on the letterhead of the manufacturer and should be signed by a person competent and having the power of attorney to bind the manufacturer. In case of foreign manufacturer, scan copy can be accepted if supported by copy of original valid normal authorization to local distributor is submitted along with above format.

The Director,
National Institute of Animal Biotechnology (NIAB),
D. No. 1-121/1, 4th & 5th Floors,
Axis Clinicals Building, Opp. to Talkie Town,
Miyapur, Hyderabad, Telangana, India - 500 049.

Sir,

We _____ who are established and reputed manufacturers of the equipment having factories at _____ (address of factory) do hereby authorize M/s. _____ (Name and address of Agent) on our behalf to submit a bid, negotiate and receive the order from you against your tender No. _____ dt. _____.

We hereby extend our full support, guarantee and warranty as per the Terms and Conditions of this Tender/PO (issued if any) for the goods and services offered by the above firm as per this tender.

Competent Authority to sign:
Name, Designation :
Date with stamp & seal of organisation:

(FORM NO- 6)
UNDERTAKING TO SUBMIT PERFORMANCE BANK GUARRNATEE

The Director,
National Institute of Animal Biotechnology (NIAB),
D. No. 1-121/1, 4th & 5th Floors,
Axis Clinicals Building, Opp. to Talkie Town,
Miyapur, Hyderabad, Telangana, India - 500 049

Sub:- Assurance for PBG

Sir,

We the Firm are participating in your Tender No _____

If our bid is accepted against this subject tender notice, we commit to provide a performance security for due performance of the contract as per NIAB policy/format/form and warranty-guarantee as per tender specification or agrees as per contract valid for 60 days more than the contract period.

Thank you.

Date with stamp & seal of organization

ORGANISATIONAL DETAILS

1	Name & Address of the applicant with Telephone No./Fax No./ Email ID	
2	Address of local office (in Hyderabad/India)	
3	Year of Establishment	
4	Legal status of the applicant (attach copies of original document defining the legal status) a) A proprietary firm b) A firm in partnership c) A limited company or Corporation / Joint venture / Consortia /Any other	
5	Names of Directors & other Key executives with designation to be connected to this work . Designation of individuals authorized to act on behalf the organization.(Contac No /E mail ID)	
6	Details of Manufacturing /Fabrication unit a. Address b. Area of the unit c. Total staff d. Tools and Equipment details	
7	Has the bidder, or any constituent partner in case of partnership firm / limited company/ Joint venture, ever been convicted by the court of law ? if so, give details.	
8	Any other information considered necessary from your side but not included above.	
9	Confirm that the Bidder has not been banned OR delisted/blacklisted by any Government or Quasi Government agencies or Public Sector Units.	
10	Confirm that Bidder is not under Liquidation, court Receivership or similar proceedings.	
COMPETENT AUTHORITY NAME , SIGN & DATE WITH STAMP & SEAL OF ORGANIZATION		

(FORM NO – 8)

FINANCIAL INFORMATION

The details to be furnished duly supported by figures in balance sheet/profit and loss account and relevant authorized documents.

Date

To,
Director
NIAB Hyderabad

I the undersigned certify that the following details submitted by the firm are verified by me and are found to be correct.

S.No.	Financial / Accounting Year	Annual Turnover (Rs.)	Profit (Rs.)	Loss (Rs.)
1	2016-2017			
2	2015-2016			
3	2014-2015			
4	2013-2014			
5	2012-2013			
AVERAGE TURNOVER OF LAST FIVE YEARS =				

Name & Signature of Chartered Accountant
with seal /stamp & contact details

(FORM NO - 9)

MAJOR WORKS OF SIMILAR CLASS COMPLETED DURING THE LAST 5 YEARS.

Please submit the following details as per format mentioned herewith.

- Select the year as per the date **of Purchase order falls in from Jan to Dec.**
- Credential issued by the Clients shall be enclosed. Details of major works executed to be enclosed.
- Work should have been executed by the firm under the name in which they are submitting the applications.
- Write NIL if no data is available in any of the following year.

Format of major works completed.

PO date should fall in Jan to Dec period of above year. Please give details of each year separately as per this format

SN	Details	2012 (Jan to Dec)	2013 (Jan to Dec)	2014 (Jan to Dec)	2015 (Jan to Dec)	2016 (Jan to Dec)
1	Purchase/Work order date and Number					
2	Name of the work/project and location					
3	Name of the Client					
4	Cost of work in Lakhs					
5	Date of start of the project					
6	Actual Date of Completion of project					
7	Period of Completion (No of days)					
8	Name and address/telephone number of officer to whom reference may be made					
9	Final value of the project					
10	Is Project completed in stipulated time as per contract or with extension of time. Reasons for the variation in cost / delay in completion if any.					
11	Whether carried out as prime Contractors or sub-contractor					

(Above data to be supported by relevant documents)

(FORM NO – 10)

DETAILS OF WORK ORDER/ PO RECEIVED FROM JAN 2017 TO TILL DATE
OF SIMILAR WORK.

PERIOD FROM JAN 2017 TO TILL DATE

SN	Purchase/Work order date and Number	Name of the work/project and location	Name of the Client	Cost of work in Lakhs	Date of start of the project	Name and address/telephone number of officer to whom reference may be made

**COMPETENT AUTHORITY NAME , SIGN & DATE
WITH STAMP & SEAL OF ORGANIZATION**

(FORM NO – 11)

BANK ACCOUNT PARTICULARS

1. BIDDER'S NAME
2. ADDRESS OF BIDDER
3. PARTICULAR OF BANK ACCOUNT
4. ACCOUNT NUMBER
5. NAME OF THE BANK
6. NAME OF THE BRANCH
7. BRANCH CODE
8. ADDRESS OF THE BANK
9. MIRCR & IFSC CODE
10. TYPE OF ACCOUNT (SB, CURRENT, CASH, CREDIT)

**COMPETENT AUTHORITY NAME , SIGN & DATE
WITH STAMP & SEAL OF ORGANIZATION**

UNDERTAKING BY BID SUBMITTING FIRM
ON FIRMS LETTERHEAD
TO BE SUBMITTED ALOGWITH TECHNICAL BID

I/We undersigned agrees:

1. We hereby agree to fully comply with, abide by and accept without variation, deviation or reservation all technical, commercial and other conditions whatsoever of the Bidding Documents and Addendum to the Bidding Documents, if any, for subject work issued by NIAB.
2. We hereby further confirm that any other terms and conditions if mentioned in our bid other than /not in compliance with tender conditions (Un-priced as well as Priced Part), shall not be recognized and shall be treated as null and void.
3. That should I/We fail to commence the work specified in this tender document, the NIAB without prejudice to any other right or remedy shall be at liberty to forfeit the earnest money. Otherwise the said earnest money shall be retained and adjusted towards security deposit.
4. To execute all the works referred to in the tender documents upon the terms and conditions contained or referred to therein/ mentioned in Purchase/Work Order.
5. I have submitted all the information, supporting documents as per the format asked in this tender document and submitted DD as required for EMD as Bid Security /Tender processing fees..

The names and postal addresses and contract phone nos. of our representative(s) authorized to deal with this tender are:

- 1)
- 2)
- 3)

**COMPETENT AUTHORITY NAME , SIGN & DATE
WITH STAMP & SEAL OF ORGANIZATION**

BANK SOLVENCY CERTIFICATE

Note:- Banker's certificate should be on letter head of the Bank and should not be more than 4 months old from the date of publication of tender.

Date:

To,
The Director
NIAB - Hyderabad

BANK SOLVENCY CERTIFICATE

We the **(Bank Name)** do hereby certify that **(Name of Firm)** having their Registered office at **(Registered Office Address)** is solvent to the extent of Rs. _____ in words _____) as disclosed by the information and records which are available with the aforesaid bank.

It is further notified that this certificate is being issued at the request of **(Name of Firm)** without attaching any risk and responsibility on our part in any respect whatsoever more particularly either as guarantor or otherwise.

Sign & Stamp of Bank Manager

Place:

Date:

CERTIFICATE OF NIAB SITE INSPECTION
TO UNDERSTAND THE WORK AND SCOPE OF TENDER

Certified that our firm.....representative have visited the NIAB site as per following details and assessed the nature and scope of work involved before submitting our offer. We will be able to complete the work within the stipulated time and final price submitted in our proposal has been calculated including all requirements/cost factor for this work.

Address	Date & time of visit	Name of person visited with contact details.
Address National Institute of Animal Biotechnology (NIAB), Survey No 37/4, Gopanally Village , Gowalidoodi Area , Serilingampalli Mandal beside Yellamma Temple , Near petrol Pump , RR District, and Hyderabad 500046. Land Mark :- Gowalidoodi Area , near Yellamma Temple , Near Petrol Pump , TIFR upcoming Campus , Gopanally Road ,Near nankramguda / Q City .		

Please inform to S&P section /send E mail / to santosh@niab.org.in / 040-23049405 and give information about date and time, name of person visiting to NIAB site before visiting the site.

Site visit is mandatory . If you do not visit the site of NIAB , your Bid will be rejected and No queries will be entertained.

TECHNICAL BID COMPLIANCE FORM
(VERY IMPORTANT DOCUMENT TO BE SUBMITTED)

The Director,
National Institute of Animal Biotechnology (NIAB),
D. No. 1-121/1, 4th & 5th Floors,
Axis Clinicals Building, Opp. to Talkie Town,
Miyapur, Hyderabad, Telangana, India - 500 049

Sir,

Please find attached technical compliance statement as required vide this Tender No _____ dt _____
For the item _____

Sr No.	Item/work Specifications (As per Chapter No 6)	Bidder's Specifications /Offer	Compliance (Yes/No)	Catalogue Page No/Bid Page No. on which compliance information is given & which is attached in the bid submitted.	Remark /Deviation (If any)

******* Please note following very very important points *******

An item-by-item commentary on the Purchaser's Technical Specifications demonstrating substantial responsiveness of the goods and services to those specifications or a statement of deviations and exceptions to the provisions of the Technical Specifications must be provided. If any deviation is proposed by the Bidder, the same must be clearly indicated and enclosed as deviation as per given format. Compliance/Deviation statement comparing the specifications of the quoted model to the required specifications should also give the page number(s) of the technical literature where the relevant specification is mentioned. Bids must have supporting documents (technical literature or copies of relevant pages from the service manual or factory test data) for all the points of specification, failing this will result in rejection of bid.

The technical committee can ask for demo in NIAB (if required at the time of technical evaluation). If bid participating firm fails to arrange for demo, it will result in rejection of the bid on the ground of failure to arrange for demo..No Queries will be entertained for waive off for demo as it is in utmost interest of the organisation to make correct procurement as per end user requirement and use public fund in correct manner with avoid of risk of purchase of substandard material. As specification is essence of this purchase no comprise will be made in ascertaining the right quality of product as per requirement for NIAB.

Details of material specification to be used as per quotation of firm

**Please read tender technical speciation mentioned and submit following details.
Write NA IF Not Applicable**

Please submit this details about the brand/make which you will be using in this work/item.

Sl. No.	Item Description	Material	Thickness/Gauge / Final Surface Finish / Coating	Make/Brand	Remarks/Make Brand

PRICE BID FORMAT --- PRICE SCHEDULE 'A'

(To be utilised by the bidders for quoting their prices).

Please prepare price bid on your letter head as per this format and upload it in with other required format. You can also upload your detail quotation on your firm letterhead along with this format.

Item. No	Item Description (Please read chapter NO 6 for detail specification)	Qty	Unit Cost inclusive of tax	Total Cost inclusive of tax
1	L3 Core Switch	1		
2	Access Switch with 24 port switch	16		
3	Access Switch with 24 port PoE+ switch	2		
4	Access Switch with 8 port PoE+ switch	8		
5	Wifi Controller with 20 nos of AP licenses	1		
6	Wifi Access Points - Indoor	14		
7	Wifi Access Points - Outdoor	1		
8	1G SFP Single Mode fiber transceivers	35		
9	10G SFP+ Multi Mode fiber transceivers	2		
10	DAC Cable 1M	24		
11	LIU Loaded for 24 Cores	4		
12	LIU Loaded for 6 Cores	15		
13	LC-LC SM OFC Patch Cords 3 Mtr	35		
14	LC-LC MM OFC Patch Cords 15 Mts	5		
15	CAT6 UTP Patch Cords, Factory Crimped, 1.5 Mtrs	500		
16	CAT6 UTP Patch Cords, Factory Crimped, 3 Mtrs	400		
17	12 U Network Rack	5		
18	6 U Network Rack	10		
19	42 U Network Rack	1		
20	Jack Panel Fully Loaded with Cat6 IOs	25		
21	Services – Network Deployment, Configuration as per Approved NIAB design and commissioning.			
	Total Cost including Tax			
	Final Cost The firm should quote the price for above specification and Final Cost of this full project supply , installation , testing of IT/Networking requirements as per specification , including cost and other incidental expenses as per specification above to NIAB main campus NIAB, Survey No. 37, Gopanpally Village, Serilingampally, RR District ,TS) including warranty & AMC mentioned in NIT.			

Please give your brand /make clearly in your quotation.

Please make a note of that GST for NIAB is 5 % as per GOI, MoF Notification No. 45 /2017 & 47/2017 dt. 14/11/2017 as it is registered with DSIR and items are used for Research purpose only. Custom duty exemption as per 51/96 is applicable to NIAB. (Applicable wherever necessary)

PRICE SCHEDULE 'B'

**Cost of any other optional accessories /spare/consumable
Suitable as per specification/suggested by vendor which is not mentioned in tender.**

Sr No	Description	Cost per unit

DECLARATION TO BE SUBMITTED WITH PRICE BID

I /We the undersigned have read and considered all the above points carefully as per Chapter -3 before preparing the bid and noted all the points. The price bid will be prepared considering all the above points. The best possible break up of all the prices unit and total up to delivery and installation of the item in tender up to NIAB premise / location for delivery , standard & Extra Warranty , AMC has been mentioned in price bid. Prices quoted shall remain fixed during the entire period of contract and shall not be subject to variation on any account.

Competent authority sign , date with stamp & seal of organization

CHAPTER - 6
SPECIFICATION AND OTHER TERMS OF REQUIREMENTS

Technical specification

Technical Specifications Compliance (to be part of BID)			
Item No-1	CORE SWITCH	Quantity- 1	
	SPECIFICATION	Compliance Yes/No	Remarks/Make Brand
A	Product details- Please specify		
1	Please mention Make, Model No. and Part Code of L3 Core Switch		
B	Architecture & Port Density		
1	Switch should offer Wire-Speed Non-Blocking Switching & Routing Performance at Layer 2 & Layer 3 from Day-1 on All Ports.		
2	Switch should support 1G , 10G , 40G from Day-1		
3	The core Switch should have Twenty four (24) 1GbE SFP & 10GbE SFP+ ports from day 1 populated with 1GBE SFP Single Mode modules.		
4	Switch should support Stacking up to 8 Switches with more than 80 Gbps stacking bandwidth per Switch.		
C	Performance		
1	Switching Bandwidth: Should provide Non-Blocking switch fabric capacity of 1Tbps or more.		
2	Forwarding Capacity: Should provide wire-speed packet forwarding of 756 Mpps or more.		
D	Layer 2 features		
1	Should support 4000 active VLANs		
2	Should support 80,000 MAC addresses or more.		
3	Shall support IP multicast snooping IGMP v1, v2, v3		
4	Should support Jumbo Frames (up to 9000 bytes)		
E	Layer 3 features		
1	Should support minimum 55K or more IPv4 routes & 6000 or more IPv6 routes		
2	Should support Basic IPv4 and IPv6 Static Routing, ECMP, Host Routes, Virtual Interfaces, Routed Interfaces, Route Only and Routing between directly connected subnets from day 1.		
3	Should support the following Dynamic IPv4 & IPv6 Routing protocols and Multicast Routing Protocols from day 1.		
4	Dynamic IPv4 and IPv6 Routing protocols like RIP v1&v2, RIPng, OSPFv2, OSPFv3, BGP4, BGP4+, Multi-VRF, VRRPv2 & VRRPv3 from Day 1.		
5	PIM-SSM, PIM Sparse, PIM Dense, PIM Anycast RP, and PIM passive IPv4 multicast routing from Day 1		
6	IPv4 Multicast Non-stop routing (NSR) support for PIM-SM, SSM, and Anycast RP from Day 1		
7	PIM-SSM, PIM Sparse, PIM Anycast RP, MSDP and PIM6-SM Snooping IPv6 multicast routing from Day 1		
F	Security		
1	Switch should support RADIUS, TACACS/TACACS+ and username/password for Authentication, Authorization and Accounting (AAA) with Local User Accounts and Local User Passwords.		
2	Should support secure communications to the management interface and system through SSL, Secure Shell (SSHv2), Secure Copy and SNMPv3		
3	Should support IP Source Guard, DHCP snooping, DHCPv4, DHCPv6 and Dynamic ARP Inspection.		

4	Should support IPv4 and IPv6 ACLs with up to 2000 rules per ACL and a minimum of 6000 rules per system (Stand alone Switch or Stack).		
5	Should support Byte and packet based broadcast, multicast, and unknown-unicast limits with suppression port dampening.		
6	Should support IPv6 Router Advertisement (RA) Guard.		
7	Should support Flexible Authentication with 802.1x Authentication and MAC Authentication.		
G	Manageability		
1	Should support manageability using Network Management Software with Web based Graphical User Interface (GUI).		
2	Switch's Operating System should have industry standard Command Line Interface (CLI).		
3	It should have Telnet, TFTP, HTTP access to switch management/monitoring		
4	Should support NetFlow or sFlow or IPFIX or equivalent		
H	Physical Attributes, Power Supply and Fans		
1	Mounting Option : 19" Universal rack mount ears		
2	Should be loaded with dual hot swappable, redundant load sharing AC power supplies to provide 1:1 power supply.		
3	Should be loaded with redundant hot swappable fans.		
4	Operating Temperature should be 0° C to +50° C		
I	Mandatory Compliance :		
1	All categories of Switches, Transceivers & Switch OS should be from same OEM		
2	Both Switch and Operating system should Be NDPP Certified.		
J	Warranty		
1	Switch should be quoted with TAC Support and Warranty for 5 years with NBD Hardware Replacement.		
K	Product brochure		
1	Vendor should provide printed technical catalogs/brochures for the quoted model containing technical specifications, features.		

Item No -2	Access Switch - 24 port switch	Quantity- 16	
	SPECIFICATION	Compliance Yes/No	Remarks/Make Brand
A	Product details- Please specify		
1	Please mention Make, Model No. and Part Code		
B	Architecture & Port Density		
1	Switch should offer Wire-Speed Non-Blocking Switching & Routing Performance at Layer 2 & Layer 3.		
2	The Access Switch should have Twenty Four (24) 1GbE RJ45 ports and should have Four 1GbE/10GbE SFP+ Port from Day-1 .		
3	Access Switch should support Stacking of 8 Switches or more with more than 40 Gbps stacking bandwidth per Switch.		
C	Performance		
1	Switching Bandwidth: Should provide Non-Blocking switch fabric capacity of 128 Gbps or more.		
2	Forwarding Capacity: Should provide wire-speed packet forwarding of 95 Mpps or more.		
D	Layer 2 features		
1	Should support 4000 or more VLANs		
2	Should support 16,000 MAC addresses or more.		

3	Shall support IP multicast snooping with support for IGMP v1, v2, v3 and MLD v1 & v2		
4	Should support Jumbo Frames (up to 9000 bytes)		
E	Layer 3 features		
1	Should support minimum 1000 IPv4 & IPv6 routes		
2	Should support Basic IPv4 and IPv6 Static Routing, ECMP, Host Routes, Virtual Interfaces, Routed Interfaces, Route Only and Routing between directly connected subnets from day 1.		
3	Should have an optional upgrade path, preferably software licensed based, to support the following Dynamic IPv4 & IPv6 Routing protocols and Multicast Routing Protocols.		
4	Dynamic IPv4 and IPv6 Routing protocols like RIP v1&v2, RIPng, OSPFv2, OSPFv3, VRRPv2 & VRRPv3 from Day 1.		
5	PIM-SSM, PIM Sparse, PIM Dense, PIM Anycast RP, and PIM passive IPv4 multicast routing		
6	PIM-SSM, PIM Sparse, PIM Anycast RP and PIM6-SM Snooping IPv6 multicast routing		
F	Security		
1	Switch should support RADIUS, TACACS/TACACS+ and username/password for Authentication, Authorization and Accounting (AAA) with Local User Accounts and Local User Passwords.		
2	Should support secure communications to the management interface and system through SSL, Secure Shell (SSHv2), Secure Copy and SNMPv3		
3	Should support IP Source Guard, DHCP snooping, DHCPv4, DHCPv6 and Dynamic ARP Inspection.		
4	Should support IPv4 and IPv6 ACLs with up to 500 rules per ACL and a minimum of 6K rules per system (Standalone Switch or Stack).		
5	Should support Byte and packet based broadcast, multicast, and unknown-unicast limits with suppression port dampening.		
6	Should support IPv6 Router Advertisement (RA) Guard.		
7	Should support Flexible Authentication with 802.1x Authentication and MAC Authentication.		
G	Manageability		
1	Should support manageability using Network Management Software with Web based Graphical User Interface (GUI).		
2	Switch's Operating System should have industry standard Command Line Interface (CLI).		
3	It should have Telnet, TFTP, HTTP access to switch management/monitoring		
4	Should support NetFlow or sFlow or IPFIX or equivalent		
H	Physical Attributes		
1	Mounting Option : 19" Universal rack mount ears		
2	Operating Temperature should be -5° C to +45° C		
I	Mandatory Compliance :		
1	All categories of Switches, Transceivers & Switch OS should be from same OEM		
2	Both Switch and Operating system should Be NDPP Certified.		
3	Switch should comply to Vibration IEC 68-2-36, IEC 68-2-6, Shock and drop IEC 68-2-27, IEC 68-2-32		
J	Warranty		
1	Switch should be quoted with TAC Support and Warranty for 5 years with NBD Hardware Replacement.		
K	Product brochure		
1	Vendor should provide printed technical catalogs/brochures for the quoted model containing technical specifications, features.		

Item No -3	Access Switch - 24 port PoE+ switch	Quantity- 2	
	SPECIFICATION	Compliance Yes/No	Remarks/Make Brand
A	Product details- Please specify		
1	Please mention Make, Model No. and Part Code		
B	Architecture & Port Density		
1	Switch should offer Wire-Speed Non-Blocking Switching & Routing Performance at Layer 2 & Layer 3.		
2	The Access Switch should have Twenty Four (24) 1GbE PoE+ RJ45 ports and should have Four 1GbE/10GbE SFP+ Port from Day-1 .		
3	Access Switch should support Stacking of 8 Switches or more with more than 40 Gbps stacking bandwidth per Switch.		
C	Performance		
1	Switching Bandwidth: Should provide Non-Blocking switch fabric capacity of 128 Gbps or more.		
2	Forwarding Capacity: Should provide wire-speed packet forwarding of 96 Mpps or more.		
D	Layer 2 features		
1	Should support 4000 or more VLANs		
2	Should support 16,000 MAC addresses or more.		
3	Shall support IP multicast snooping with support for IGMP v1, v2, v3 and MLD v1 & v2		
4	Should support Jumbo Frames (up to 9000 bytes)		
E	Layer 3 features		
1	Should support minimum 1000 IPv4 & IPv6 routes		
2	Should support Basic IPv4 and IPv6 Static Routing, ECMP, Host Routes, Virtual Interfaces, Routed Interfaces, Route Only and Routing between directly connected subnets from day 1.		
3	Should have an optional upgrade path, preferably software licensed based, to support the following Dynamic IPv4 & IPv6 Routing protocols and Multicast Routing Protocols.		
4	Dynamic IPv4 and IPv6 Routing protocols like RIP v1&v2, RIPng, OSPFv2, OSPFv3, VRRPv2 & VRRPv3.		
5	PIM-SSM, PIM Sparse, PIM Dense, PIM Anycast RP, and PIM passive IPv4 multicast routing		
6	PIM-SSM, PIM Sparse, PIM Anycast RP and PIM6-SM Snooping IPv6 multicast routing		
F	Security		
1	Switch should support RADIUS, TACACS/TACACS+ and username/password for Authentication, Authorization and Accounting (AAA) with Local User Accounts and Local User Passwords.		
2	Should support secure communications to the management interface and system through SSL, Secure Shell (SSHv2), Secure Copy and SNMPv3		
3	Should support IP Source Guard, DHCP snooping, DHCPv4, DHCPv6 and Dynamic ARP Inspection.		
4	Should support IPv4 and IPv6 ACLs with up to 500 rules per ACL and a minimum of 6K rules per system (Standalone Switch or Stack).		
5	Should support Byte and packet based broadcast, multicast, and unknown-unicast limits with suppression port dampening.		
6	Should support IPv6 Router Advertisement (RA) Guard.		
7	Should support Flexible Authentication with 802.1x Authentication and MAC Authentication.		
G	Manageability		
1	Should support manageability using Network Management Software with Web based Graphical User Interface (GUI).		
2	Switch's Operating System should have industry standard Command Line Interface (CLI).		

3	It should have Telnet, TFTP, HTTP access to switch management/monitoring		
4	Should support NetFlow or sFlow or IPFIX or equivalent		
H	Physical Attributes & PoE Power Budget		
1	Mounting Option : 19" Universal rack mount ears		
2	PoE Power Budget : The Switch should provide 360 watts of PoE+ power.		
3	Operating Temperature should be -5° C to +45° C		
I	Mandatory Compliance :		
1	All categories of Switches, Transceivers & Switch OS should be from same OEM		
2	Both Switch and Operating system should Be NDPP Certified.		
3	Switch should comply to Vibration IEC 68-2-36, IEC 68-2-6, Shock and drop IEC 68-2-27, IEC 68-2-32		
J	Warranty		
1	Switch should be quoted with TAC Support and Warranty for 5 years with NBD Hardware Replacement.		
K	Product brochure		
1	Vendor should provide printed technical catalogs/brochures for the quoted model containing technical specifications, features.		

Item No- 4	Access Switch - 8 port PoE+ switch – 8 nos	Quantity- 8	
	SPECIFICATION	Compliance Yes/No	Remarks/Make Brand
A	Product details- Please specify		
1	Please mention Make, Model No. and Part Code		
B	Architecture & Port Density		
1	Switch should offer Wire-Speed Non-Blocking Switching & Routing Performance at Layer 2 & Layer 3.		
2	The Access Switch should have Twelve (8) 1GbE PoE+ RJ45 ports and should have Two 1GbE/10GbE SFP+ Port from Day-1 .		
3	Access Switch should support Stacking up to 8 Switches with more than 40 Gbps stacking bandwidth per Switch.		
C	Performance		
1	Switching Bandwidth: Should provide Non-Blocking switch fabric capacity of 56 Gbps or more.		
2	Forwarding Capacity: Should provide wire-speed packet forwarding of 48 Mpps or more.		
D	Layer 2 features		
1	Should support 4000 or more VLANs		
2	Should support 16,000 MAC addresses or more.		
3	Shall support IP multicast snooping with support for IGMP v1, v2, v3 and MLD v1 & v2		
4	Should support Jumbo Frames (up to 9000 bytes)		
E	Layer 3 features		
1	Should support minimum 1000 IPv4 & IPv6 routes		
2	Should support Basic IPv4 and IPv6 Static Routing, ECMP, Host Routes, Virtual Interfaces, Routed Interfaces, Route Only and Routing between directly connected subnets from day 1.		
3	Should have an optional upgrade path, preferably software licensed based, to support the following Dynamic IPv4 & IPv6 Routing protocols and Multicast Routing Protocols.		
4	Dynamic IPv4 and IPv6 Routing protocols like RIP v1&v2, RIPv6, OSPFv2, OSPFv3, VRRPv2 & VRRPv3.		
5	PIM-SSM, PIM Sparse, PIM Dense, PIM Anycast RP, and PIM passive IPv4 multicast routing		
6	PIM-SSM, PIM Sparse, PIM Anycast RP and PIM6-SM Snooping IPv6 multicast routing		
F	Security		

1	Switch should support RADIUS, TACACS/TACACS+ and username/password for Authentication, Authorization and Accounting (AAA) with Local User Accounts and Local User Passwords.		
2	Should support secure communications to the management interface and system through SSL, Secure Shell (SSHv2), Secure Copy and SNMPv3		
3	Should support IP Source Guard, DHCP snooping, DHCPv4, DHCPv6 and Dynamic ARP Inspection.		
4	Should support IPv4 and IPv6 ACLs with up to 500 rules per ACL and a minimum of 6K rules per system (Standalone Switch or Stack).		
5	Should support Byte and packet based broadcast, multicast, and unknown-unicast limits with suppression port dampening.		
6	Should support IPv6 Router Advertisement (RA) Guard.		
7	Should support Flexible Authentication with 802.1x Authentication and MAC Authentication.		
G	Manageability		
1	Should support manageability using Network Management Software with Web based Graphical User Interface (GUI).		
2	Switch's Operating System should have industry standard Command Line Interface (CLI).		
3	It should have Telnet, TFTP, HTTP access to switch management/monitoring		
4	Should support NetFlow or sFlow or IPFIX or equivalent		
H	Physical Attributes & PoE Power Budget		
1	Mounting Option : 19" Universal rack mount ears		
2	PoE Power Budget : The Switch should provide 124 watts of PoE+ power.		
3	Operating Temperature should be -5° C to +45° C		
I	Mandatory Compliance :		
1	All categories of Switches, Transceivers & Switch OS should be from same OEM		
2	Both Switch and Operating system should Be NDPP Certified.		
3	Switch should comply to Vibration IEC 68-2-36, IEC 68-2-6, Shock and drop IEC 68-2-27, IEC 68-2-32		
J	Warranty		
1	Switch should be quoted with TAC Support and Warranty for 3 years with NBD Hardware Replacement.		
K	Product brochure		
1	Vendor should provide printed technical catalogs/brochures for the quoted model containing technical specifications, features.		

Item No- 5	Wireless LAN (Controller)	Quantity- 1	
	SPECIFICATION	Compliance Yes/No	Remarks/Make Brand
A	Essential Features:		
1	Controller should be 19" Rack mountable 1U/2U height.		
2	WLAN Controller should have minimum 2 nos. of 10/100/1000 Ethernet or SFP Ports and one Console port.		
3	Proposed Controller should be ready for supporting 20 AP's from day one with scalability for 150 AP support in future without adding any new hardware. Controller should be able to support minimum 150 campus connected AP's or more with support of seamless roaming access over L2/L3 network.		
5	Controller should support minimum 250 WLAN's		
6	Controller should have capacity to handle minimum 2000 or more Concurrent devices.		
B	General Feature		

1	Controller should provide air-time fairness between these different speed clients – slower clients should not be starved by the faster clients and faster clients should not adversely affected by slower clients.		
2	Controller should support Spectrum Analysis feature to detect interference from different sources.		
3	System Should provide real-time charts showing interference for access point, on a per-radio, per-channel basis.		
4	Ability to map SSID to VLAN and dynamic VLAN support for same SSID.		
5	support automatic channel selection for interference avoidance		
6	Controller must support 802.11k and 802.11r.		
C	Auto Deployment of AP's at different locations		
1	Access points can discover controllers on the same L2 domain without requiring any configuration on the access point.		
2	Access points can discover controllers across Layer-3 network through DHCP or DNS option		
D	Security & monitoring		
1	Controller should support following for security & Authentication:		
2	WIRELESS SECURITY: WEP, WPA-TKIP, WPA2-AES, 802.11i		
3	AUTHENTICATION : 802.1X, local database External AAA servers : Active Directory, RADIUS, LDAP		
4	System should provide DOS attacks and Intrusion Detection & Prevention and Control for any Rough Access Points.		
5	The AP should be able to scan for rogue access points and the controller should be able to locate them on a floor map. The controller should be able to send a notification to the administrator when a rogue AP has been detected.		
6	Controller should support CAPWAP/LWAPP protocol.		
7	System must be able to provide L2/L3/L4 Access Control.		
8	Controller Should support L2 Client Isolation so User cannot access each other's devices. Isolation should have option to apply on AP or SSID's.		
9	Controller should be able to create local database of up to 2000 users.		
10	Controller should support Access Control based on Identity/Role/ Device/time or Application.		
11	Support for Walled garden "Walled Garden" functionality to allow restricted access to select destinations by unauthorized wireless users.		
12	IPv4 & IPv6 support from Day 1		
13	Should support on board and external DHCP server		
14	Controller should support integrated or External AAA server including Microsoft AD and Linux based open source AAA servers.		
15	The proposed architecture should be based on controller based Architecture with thick AP deployment. While Encryption / decryption of 802.11 packets should be able to perform at the AP.		
16	The Controller should support OS/Device finger printing and device type based policies i.e allow or deny, Bandwidth rate limit, VLAN mapping.		
17	The controller shall be manageable using CLI, Telnet/SSH, HTTP based GUI and SNMPv2/v3.		
18	The controller should be able to present a customizable dashboard with information on the status of the WLAN network.		
19	The controller should be able to raise critical alarms by sending an email. The email client on the controller should support SMTP outbound authentication and TLS encryption.		
20	The vendor should specify if all features are available with the basic access controller pricing or if the support of some features require the acquisition of some licenses. The vendor should specify which feature requires which type of licensing including its cost.		

21	Controller should have inbuilt BYOD features and Guest Access management procedure where user may use internet without entering to Enterprise SSID and should be time restricted. The Guest management should be a self-service one from end user perspective without the use of any additional software.		
E	QoS features		
1	per SSID or dynamic Per user bandwidth Rate Limiting		
2	Self-healing (on detection of RF interference or loss of RF coverage) and vendor should provide their Interference mitigation techniques for same Domain interference (interference from AP's connected to same Controller) and from other AP's and 2.4Ghz devices (Microwave's, Radio's etc.)		
3	Dynamic RF management that provides the capability to pause channel scanning / adjust RF scanning intervals based on application and load presence.		
4	Capability to provide preferred access for "fast" clients over "slow" clients (11n vs. 11g) in order to improve overall network performance.		
5	System must support Band Steering where 5 Ghz clients are forced to connect over 5Ghz Radio to provide better load balancing among 2.4Ghz and 5Ghz Radios.		
6	Support advanced multicast features and WMM support to provide best performance on Video applications.		
7	Should have Voice Call Admission control		
F	Client Management		
1	The controller should provide a Guest Login portal in order to authenticate users that are not part of the organization.		
2	The solution should be able to provide a web-based application that allows non-technical staff to create Guest accounts with validity for fixed duration like hours or days.		
3	System should be able to send password direct through Email and SMS to the user.		
4	System should be able to generate one click password for single user, multiple users or single user multiple devices.		
5	System should support internal and External Database for user authentication.		
6	System should support user management features like Rate limiting based on time based WLAN Access & User profile per WLAN etc.		
G	Regulatory		
1	Wi-Fi Alliance certified		

Item No- 6	Wireless LAN (Access Points - Indoor)	Quantity- 14	
	SPECIFICATION	Compliance Yes/No	Remarks/Make Brand
A	Specifications		
1	The APs should support the 802.11a, 802.11b, 802.11g and 11n and ac standards. It should also support 802.11ac Wave 2 standard in the 5 GHz band.		
2	Simultaneous client support on dual band radio is essential.		
3	Shall provide Min 22 dBm Radio output power for both Radios'.		
4	Should support minimum 2x2 or higher MIMO on both radio bands for an aggregate capacity of 1.150Gbps		
5	The access points should be centrally managed.		
6	In some small isolated environments, the AP should be able to function as a full-fledged stand-alone access point without the requirement of a controller.		
7	Security mechanisms should be in place to protect the communication between the Access Point controller and the Access Points.		

8	Since most radio interference come from the WLAN network itself the vendor should specify what mechanisms such as beam steering/ adaptive antenna technology/ beam forming are available in combination to focus the energy on the destination STA and minimize radio interference with the surrounding of the AP. The vendor should specify if the activation of such feature is still compatible with 802.11n spatial multiplexing.		
9	Since the WLAN network will be using an unlicensed band the solution should have mechanisms that reduce the impact of interference generated by other radio equipment operating in the same band. Describe techniques supported.		
10	The access point should be able to detect clients that have dual band capability and automatically steer those client to use the 5GHz band instead of the 2.4GHz band.		
11	The antennas to be dual polarized and should be integrated inside the access point enclosure to minimize damage and create a low profile unit that does not stand out visually.		
12	The access point should have minimum 1 Gigabit Ethernet port. The AP should get powered on with 802.3 af POE and still function to its full capabilities. The AP should also support an USB port for IoT technologies.		
13	The access point should support 802.1q VLAN tagging		
14	The access point should support WPA2 enterprise authentication and AES/CCMP encryption. AP should support Authentication via 802.1X and Active Directory.		
15	Implement Wi-Fi alliance standards WMM, 802.11d, 802.11h and 802.11e		
16	The Access Point should provide for concurrent support for high definition IP Video, Voice and Data application without needing any configuration. This feature should be demonstrable.		
17	Support RF auto-channel selection by the following three methods: a) measuring energy levels on the channel; b) monitoring for 802.11 signal structures and; (c) detecting radar pulses. Other similar forms of smart selection shall also be accepted.		
18	Channel selection based on measuring throughput capacity in real time and switching to another channel should the capacity fall below the statistical average of all channels without using background scanning as a method.		
19	Should support Transmit power tuning in 1dB increments in order to reduce interference and RF hazards		
20	Device antenna gain (integrated) must be at least 3dBi and should provide automatic interference rejection of about 10dB.		
21	Should support up to 200 clients per AP		
22	Should support DHCP Option 82 in standalone mode (without Controller) as well as in Managed mode (with Controller)		
23	For troubleshooting purposes, the administrator should have the ability to remotely capture 802.11 and / or 802.3 frames from an access point without disrupting client access.		
24	Operating Temperature: 0°C - 50°C		
25	Operating Humidity: 10 % - 95% non-condensing.		
26	Should be plenum rated and comply to RoHS		
27	Should be WiFi certified; WiFi certificate to be enclosed		
28	Should be WPC approved; ETA certificate to be enclosed		
29	Device should be UL 2043 Plenum Rated.		
30	Mechanism for physical device locking using padlock /Kensington lock / equivalent. Mounting Kit should be from the same OEM.		

Item No-7	Wireless LAN (Access Points - Outdoor)	Quantity- 1	
	SPECIFICATION	Compliance Yes/No	Remarks/Make Brand
A	Specifications		
	The APs should support the 802.11a, 802.11b, 802.11g and 11n and ac standards. It should also support 802.11ac standard in the 5 GHz band.		
	The proposed access point should be 802.11ac WAVE2 and Operate in dual band radio.		
	Should support 4 spatial streams on both radio bands for a capacity of 1700 Mbps on 5Ghz and 450 Mbps on 2.4 GHz. AP should be 4x4 MIMO with 4 streams. Should support minimum 3 MU-MIMO concurrent devices.		
	The access points should be centrally managed as well capacity to work as standalone		
	It should have USB interface for IOT compatibility in future.		
	The Outdoor AP should support 40 and 80 MHz channelization and 256-QAM modulation support;		
	The access point should be able to operate in full MIMO mode with 802.3af/at POE. Alternatively the AP should also support AC/POE Injector.		
	Security mechanisms should be in place to protect the communication between the Access Point controller and the Access Points.		
	AP should have options of dual polarised integrated or external antenna for omni directional or directional coverage through pole/wall mount as per the requirement or site survey.		
	The access point should support 802.1q VLAN tagging		
	The access point should support WPA2 enterprise authentication and AES/CCMP encryption. AP should support Authentication via 802.1X and Active Directory.		
	Implement Wi-Fi alliance standards WMM, 802.11d, 802.11h and 802.11e		
	The Access Point should provide for concurrent support for high definition IP Video, Voice and Data application without needing any configuration change. This feature should be demonstrable.		
	Channel selection based on measuring throughput capacity in real time and switching to another channel should the capacity fall below the statistical average of all channels without using background scanning as a method.		
	Upto 16 BSSIDs on 2.4G radio and 5G radio for multiple differentiated user services (e.g. voice).		
	AP should have options of integrated or external antenna for 360 degree omni coverage as well directional antenna to focus on one area through pole/wall mount.		
	Should support 300 or more clients per AP.		
	Should support IPv6 from day one		
	For troubleshooting purposes, the administrator should have the ability to remotely capture 802.11 and / or 802.3 frames from an access point without disrupting client access.		
	Operating Temperature- -40°C to 65°C. Operating Humidity: up to 95% non-condensing.		
	AP should be IP67 rated. An indoor AP with third party IP67 enclosure would not be accepted.		
	Should be WiFi certified and WPC approved; ETA certificate to be enclosed		
	Mounting Kit should be from the same OEM.		
	OEM should be mentioned in Gartner/IDC Leader's Quadrant.		
	OEM should have presence in India for minimum 8 years		
	OEM should have a support Center in India.		

		Compliance	Remarks/Make Brand
Item No- 8	1G SFP Single Mode fiber transceivers		
Item No- 9	10G SFP+ Multi Mode fiber transceivers		

	Passive component		
	SPECIFICATION	Compliance	Remarks/Make Brand
Item No- 10	DAC Cable (Qty – 24nos) Should support 1G &10G, Length – 1Meter Should be from the Same Switching OEM as quoted		
Item No- 11	LIU Loaded for 24 Cores (Qty -4) (required 1 lot for 90 Cores Termination) Fiber Optic Termination Box or Splice Panel for (90 Cores), Size - 1U, 19 inch Rack Mountable with Splice Organizer Tray Pigtails - LC, Single Mode, Should Support 1G & 10G. Documentary proof to be submitted for the item.		
Item No- 12	LIU Loaded for 6 Cores Termination (Qty - 15nos for 6 cores each) Fiber Optic Termination Box or Splice Panel for (90 Cores), Size - 1U, 19 inch Rack Mountable with Splice Organizer Tray Pigtails - LC, Single Mode Should Support 1G & 10G. Documentary proof to be submitted for the item.		
Item No- 13	LC-LC SM OFC Patch Cords (Qty - 35nos) OFC Patch Cord Single Mode, Length - 3 Mtrs, Should Support 1G & 10G. Documentary proof to be submitted for the item.		
Item No- 14	LC-LC MM OFC Patch Cords (Qty - 05nos) OFC Patch Cord Multi Mode, Length - 15 Mtrs, Should Support 1G & 10G. Documentary proof to be submitted for the item.		
Item No- 15	CAT6 UTP Patch Cords (Qty - 500nos) Factory Crimped, Length - 7 Fts / 1.5 Mtrs		
Item No- 16	CAT6 UTP Patch Cords (Qty - 400nos) Factory Crimped, Length - 10 Fts / 3 Mtrs		
Item No- 17	12 U Network Rack (Qty - 5no) Wall mountable network rack, 12U / 19 inch with glass door, Lock & Key, PDU 5/16A x 5 port, Cable Manager & Accessories, 800mm depth		
Item No- 18	6 U Network Rack (Qty - 10no) Wall mountable network rack, 6U / 19 inch with glass door, Lock & Key, PDU 5/16A x 5 port, Cable Manager & Accessories, 800mm depth		
Item No- 19	42U Network Rack (Qty - 1no) Floor mountable network rack, 42U / 19 inch with Front & Rear door, Lock & Key, PDU 5/16A x 12 port, Cable Manager & Accessories, 1200mm depth, 800mm width		
Item No- 20	Jack Panel Fully Loaded (Qty – 25 Nos) 24 Port ; 1U/19” Rack Mountable IO’s – CAT6 Type		
Item No- 21	Installation & commissioning (OFC Termination, Field Cat6 cable termination in Jack panel, Rack Mounting etc and all other aspect of Network Deployment)		

OFC Layout Topology Supporting 10G Backbone Ready

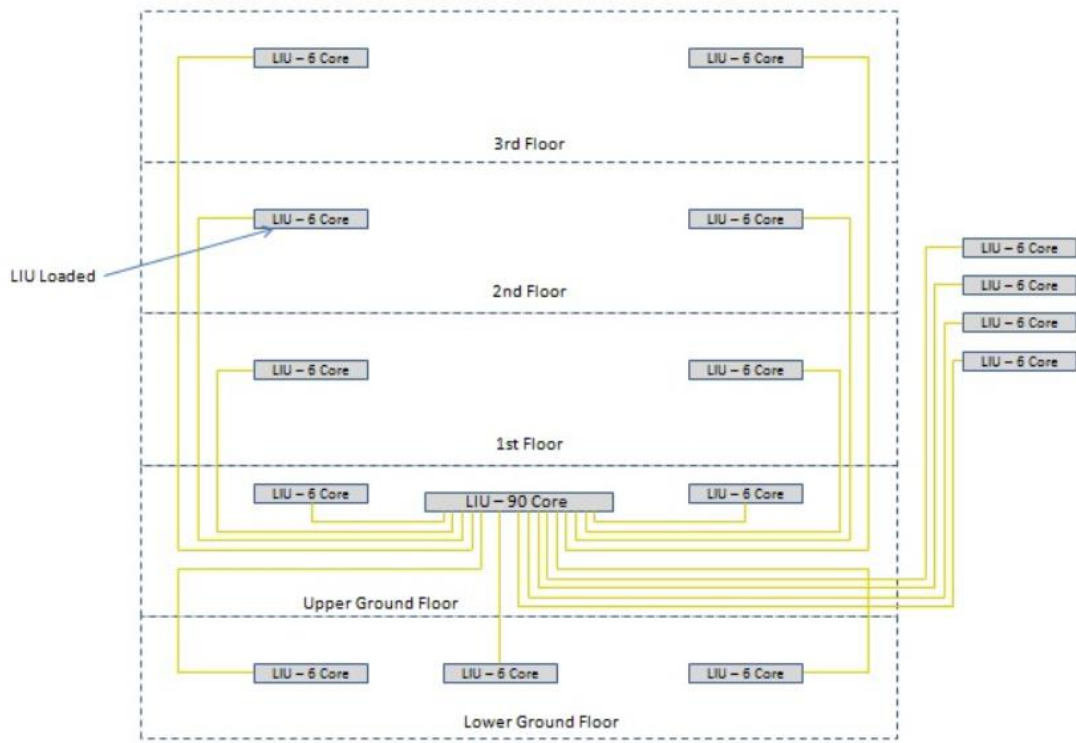

Switch Layout Topology with 10G OFC Backbone

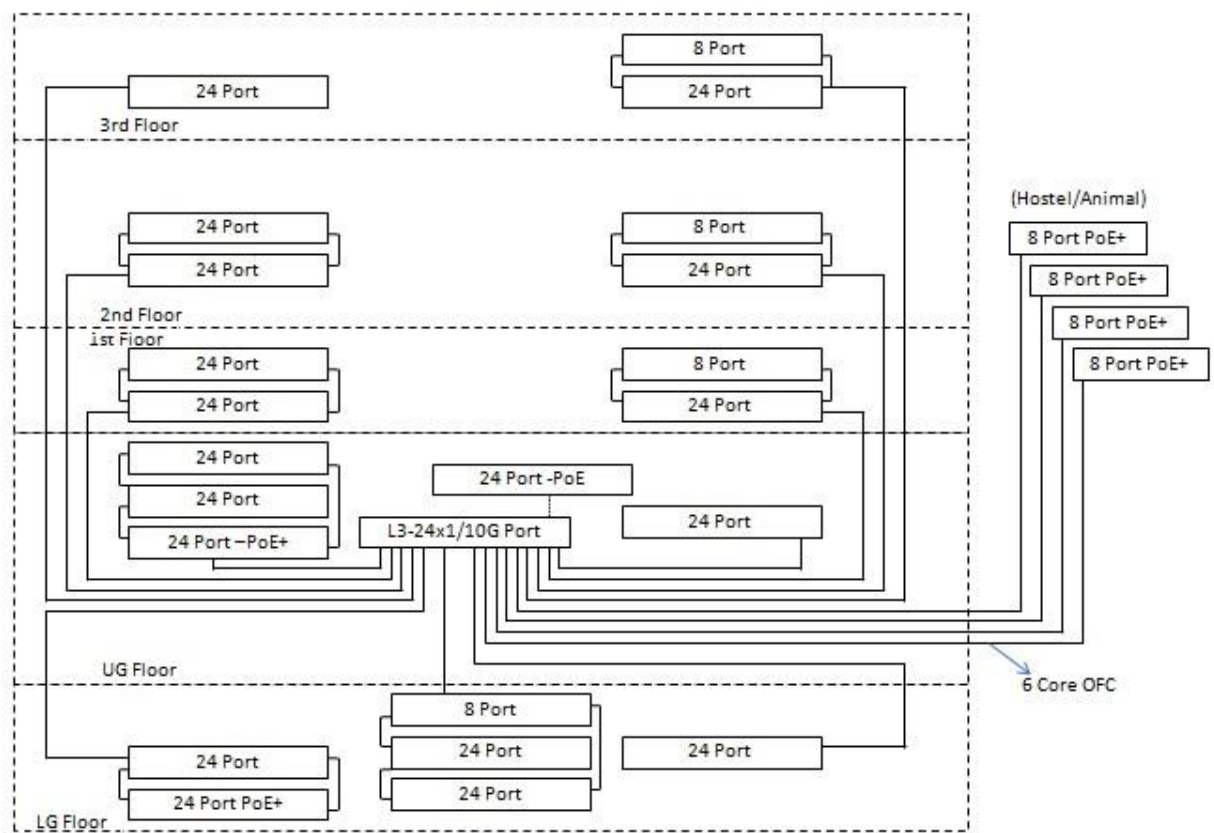

Sl. No	Pre-Qualification Criteria	Compliance Yes/No	Remarks/Make Brand
a	Company Profile including previous experience, Please attach copies of Work/Purchase Orders, Completion Certificate, etc. executed project of similar technology, scale value at Indian Organizations /Institutions. The bidder should have supplied to the Government or large Public Sector/Private Sector Organizations in India. Bidders should submit the satisfactory performance letter/ certificate from their Clients.		
b	Acceptance of all terms and conditions specified in these tender documents		
c	The bidder has to make the network functional. If any additional item is required, bidder should consider the same in their bid.		
d	Solvency Certificate obtained issued after 01- 04 -2017 by Nationalized/Schedule Commercial bank for the minimum value of INR 50 Lakhs to be submitted along with technical bid. Failure in which the tender will be rejected.		
e	Copy of valid PAN number issued by the Income-Tax Authority, GSTN No, Registration Certificate of the firm/agency/Company and proof of minimum 3 years' experience.		
f	The copy of audited financial reports/balance sheet /IT returns of the bidder for the asked financial year are required to be attached .		
g	The bidder should have Average annual sales turnover minimum INR 50 lakhs during three previous financial years ending March 31, 2017. (Proof of document to be submitted). The bidder's firm should be in profit (Proof to be submitted). Attach firm's last 3 years audited profit and loss balance sheet duly audited by C.A.		
h	The bidder and OEM should have executed at least three projects in India using the architecture and technologies similar/equal or greater scale value to those being proposed in their quotation against this tender. In addition the OEM and partner should have successfully executed at least one project together in India.		
i	The bidder should have supplied to the Government or large Public Sector/Private Sector Organizations in India. Purchase order copies of the same must be submitted with the technical bid. Bidders should submit the satisfactory performance letter/ certificate from their Clients, where they have done similar installations.		
j	All vendors participating in this tender must visit the site for site survey and also meet with the associated member for detailed discussions and clarifications, if any before bidding.		
k	All the mentioned active equipment including all Ethernet switching equipment, wifi equipment and optic fiber modules/transceivers must be from a single OEM. The patch chords (OFC/UTP) quoted for must be factory crimped.		
l	In case the Bidder is a System Integration Partner of the Principal Manufacturer, a Certificate from the Principal Manufacturer clearly stating the relationship and level of partnership with the Partner and authorization to the Partner to quote for this Specific tender Inquiry is to be furnished.		
m	The PoE+ switches proposed will power industry standard 802.11 a/b/g/n/ac wireless access points (indoor and outdoor), VoIP phones and CCTV cameras. The PoE+ switch proposed should be able to fully support such devices.		
n	The principal firm should have at least one service center at Hyderabad. The company or tenderer should have OEM certified service engineers in the relevant field of quoted item. The firm should have at least one OEM certified engineer, stationed in Hyderabad.		
o	All quotations submitted must follow the prescribed format for technical compliance as in document below. Failure to do so will result in the quotation being summarily rejected.		
p	Products offered should be supported for next five years from the date of installation and should not be declared end of sale.		
q	The supplier should not be currently blacklisted by any corporate/central/state government department / public sector unit. Undertaking for the same should be furnished by the bidder		
r	5 years comprehensive warranty is required for all equipment proposed in a quotation		
s	Equipment quoted should be Ipv6 ready and RoHS compliant.		

**COMPETENT AUTHORITY NAME , SIGN & DATE
WITH STAMP & SEAL OF ORGANIZATION**

Other important points to be noted & comply in bid submission

Scope of Work: The work consists of Supply, Installation, Testing and Commissioning of IT/Networking requirements as per specification in accordance with the approved drawings and instructions. It includes furnishing of all materials/tools as per requirement, equipment training, management and obtaining all Statutory approval/clearances by local authorities (if any) necessary incidental to the installation and completion of the work.

Firm shall visit the site: It is requested to intending bidders to visit the site Address: NIAB, Survey No. 37, Gopanpally Village, Serilingampally, RR District) and make themselves thoroughly acquainted with the site condition, nature and requirements of the work, facilities of transport conditions, effective labour and materials, access and storage for materials and removal of rubbish. The rate quoted by the contractor shall take care of all contingencies required for completion of the work to the entire satisfaction of the Purchaser, including minor civil/plumbing/electrical works if any. The tenderer shall provide in their tender for cost of carriage, freight and other charges as also for any special difficulties for proper execution of work.

ISO Certified firm can be preferred.

Technical Specifications of Materials:-The contractor will ensure and confirm that only new original and genuine items/s will be supplied.

Warranty Declaration: The Bidder/Manufacturer must give on-site WARRANTY of all the equipment from the date of commissioning and also give the warranty that everything to be supplied by them shall be free from any defects and faults in materials, workmanship and shall be of the highest quality and the equipment ordered shall be in full conformity with the specifications. If any Manufacturing, Operational defect observed during the warranty period as per NIT/PO, the Bidder shall remove/replace the defect/sub-standard material within 10 working days' time after getting written intimation from concerned Competent Authority of NIAB. Three years comprehensive warranty is preferred and further comprehensive AMC rate may be provided.

Inspection and tests: If purchaser wishes: a) The inspections shall be carried out by the appointed Technical Committee or Inspection Committee constituted by NIAB. b) In the event of the sample of items supplied failing quality test and found to be not as per specification the Purchaser is at liberty to make alternative purchase of the items, of equipment for which the supply orders have been placed, from any other sources or in the open market or from any other suppliers who might have quoted higher rate at Bid and the cost of the supplier and in such cases the Purchaser has every right to recover the excess cost from supplier's performance security/pending bill. c) If any items of items supplied by the supplier have been partially or wholly used or consumed after supply and are subsequently found to be in bad order, unsound, inferior in quality or description or otherwise faulty or unfit and if payment had already been made, then the contract price or prices of such articles or things will be recovered from the supplier. The supplier will not be entitled to any payment, whatsoever, for items of equipment found to be NOT OF STANDARD QUALITY whether used or not and the purchaser is entitled to deduct the cost of such item from any amount payable to the supplier. On the basis of nature of failure, the product / supplier will be moved for black listing. For item labelled as NOT OF STANDARD QUALITY, the administration of NIAB will be informed for initiating necessary action against the supplier and that product shall be banned / black listed and no further supplies will be accepted. The supplier shall also not be eligible to participate in tenders for supply of such equipment for a period of five subsequent years to NIAB.

Contractor to Provide Everything Necessary to make IT/Networking requirements per specification , functional as per plan / presentation by firm approved by NIAB.: The contractor shall provide everything necessary for the proper execution of the work including obtaining statutory approvals/clearances by local authorities (if any) according to the intent and meaning of the drawings, schedule of quantities and specifications taken together whether the same may or may not be particularly shown or described therein.

The rates quoted against individual items will be inclusive of everything necessary to complete the said items of work within the contemplation of the contract, and beyond the unit price no extra payment will be allowed for incidental or contingent work, labour and/ or material inclusive of all taxes and duties whatsoever except for specific items, if any, stipulated in the tender document. The contractor shall supply and install at his own cost, for the execution of any work, all tools, tackles, machinery, equipment and necessary centering, scaffolding, staging, planking, timbering, strutting, shoring, pumping, fencing, boarding, watching and lighting by night as well as by day required not only for the proper execution and protection of the said work but also for the protection of the public and safety of any adjacent roads, streets, walls, houses, buildings, all other erections, matters and things and the contractor shall take down and remove any or all such centering, scaffolding, planking, timbering, strutting, shoring etc., as occasion shall be required or when ordered so to do, and shall fully reinstate and make all good matters and things disturbed during the execution of works to the satisfaction of NIAB.

Clearing Site on Completion: On completion of the works the contractor shall clear away and remove from the site all constructional plant, surplus materials, rubbish and temporary works of every kind and leave the whole of the site and the works clean and in a workmanlike condition to the satisfaction of NIAB. The rate quoted by the contractor shall include all such contingencies.

Defects rectification after Completion of Work at NIAB: The contractor shall make good at his own cost and to the satisfaction of NIAB, all defects, shrinkage, settlements or other faults which may appear within 36 months after completion of the work. In the default, NIAB may employ and pay other persons to amend and make good such damages, losses and expenses consequent thereon or incidental thereto shall be made good and borne by the contractor and such damages, loss and expenses shall be recoverable from contractor by NIAB or may be deducted by the employer from any money due to the contractor; in the event of the amount retained being insufficient, balance will be recovered from the contractor from the amount retained i.e. from Performance Security. **Time of Completion, Extension of Time: Time of Completion:** The entire work is to be completed in all respects within 45 (Forty Five) Days. The work shall deemed to be commenced within 5 days from the date of acceptance letter or date of handing over of site, whichever is earlier. Time is the essence of the contract and shall be strictly observed by the contractor. The work shall not be considered as complete until NIAB certifies in writing that this has been completed and the defects liability period shall commence from the date of such certificate.

IMPORTANT NOTE: - PLEASE READ CHAPTER 5 AND 6 CAREFULLY AND KEEP SCANNED FORMAT DOCUMENTS READY IN ONE PDF FILE BEFORE SUBMISSION OF THE BID.

- **Take DD and scan it in pdf format. Write Tender No , Name of Firm , Contact No on backside of DD. Send the DD to NIAB- Hyderabad Address as per due date.**
- **Read Chapter No 5 & 6 carefully & Keep required documents ready, scan it in pdf file to be uploaded in Cover -1.**
- **TENDER PROCESSING CHARGES Rs 1500 /- is mandatory for all firms and not exempted to any firm. This Tender document is free of cost and no tender fees is applicable. EMD exemption is as rules mentioned herein.**

OTHER IMPORTANT REQUIREMENTS WITH SPECIFICATION

- I. Only competent firm who can supply the material as per required specification should submit the Bid with supporting technical documents as the specification is essence of the this procurement. Technical Bid Compliance Form and information/ important points mentioned therein as per tender document along with supporting documents, product brochure / technical literature/Catalogue / product website details (if any) must be submitted along with Bid. If this is not submitted as per format mentioned in this tender document, the bid will be rejected with the reason (Failing compliance of Specification- OTHER REQUIREMENTS - (I) - and no correspondence will be made to firm in this regard & No queries will be entertained in this regard from firm. Simply mentioning complied/yes without supporting documents will result in rejection of Bid and blacklisting of firm from future participation of NIAB tenders.
- II. All the items required to make required instrument functional must be quoted as main offer. No hidden cost should be mentioned as optional accessories. Optional accessories (if any) which is not related with making instrument functional, should be quoted separately.
- III. Local Service Support in Hyderabad with contact details & details of installations completed in Hyderabad of the similar model should be submitted along with your bid.
- IV. Extended Comprehensive Warranty (with spares& Service) for 3 years and AMC (without spares only service support) for 3 years for the instrument/item required /as per this NIT should be quoted separately by the firm. This is to be quoted as extra item over & above of the standard warranty/ AMC offered by bidder/As per tender.
- V. If any brand is mentioned in the specification it means that brand or substantially equivalent reputed brand may be considered at the discretions of competent authority.
- VI. TENDER PROCESSING CHARGES Rs 1500 /- is mandatory for all firms and not exempted to any firm. This Tender document is free of cost and no tender fees is applicable. EMD exemption is as rules mentioned herein.

Few of the conditions/ forms in this document may not be applicable for Service/Work requirement as per this tender. Write "NA" in any of the form wherever it is suitable/applicable as per bid submitting firm considering the requirement in tender.

Please read very carefully evaluation criteria mentioned in chapter - 3, point No 15 & 16. Considering these points, firms are informed to submit all relevant supporting documents which will give them better marks in technical criteria.

(How to find NIAB tenders in CPPP website.)

You can find our tenders on CPPP website under following link and selection mentioned below

Go to website <https://eprocure.gov.in/eprocure/app> then click [Tenders by Organisation](#) and then click Organisation Name --- **Department of Biotechnology--** you will find NIAB Tenders.

Also Tender link is available on NIAB website.

Go to <http://www.niab.org.in/Default.aspx> then click (Tenders) then click ([The following tenders may be viewed on the website of Central Public Procurement Portal](#))

For any queries you can send E mail to us santosh@niab.org.in, spm@niab.org.in .